

## Checking brake pads

### Front wheel

#### Tools required

- Allen keys
- 4 mm,
- 8 mm.

Screwdriver with reversible blade.

#### Procedure

- Place motorcycle on center stand.
- Take off front wheel fairing (page 49).
- Remove fastening screws (1) for left/right brake calipers.
- Carefully remove brake calipers.

- Check/measure thickness of brake pads (2).  
Minimum pad thickness:  
**1.5 mm (0.06 in)**
- Refit brake calipers in the reverse order.

#### Tightening torque

- Brake caliper screws (1)  
⇒ **32 Nm (23 ft.lb.)**

#### Note

Have work performed on brake system by your BMW motorcycle dealer or a qualified service technician.

#### Caution

Do not damage brake discs and pads when removing and installing brake calipers!

Do not operate handbrake lever with brake calipers removed!

Ensure brake pads have at least minimum thickness!

Have tightening torques checked by a qualified service technician!

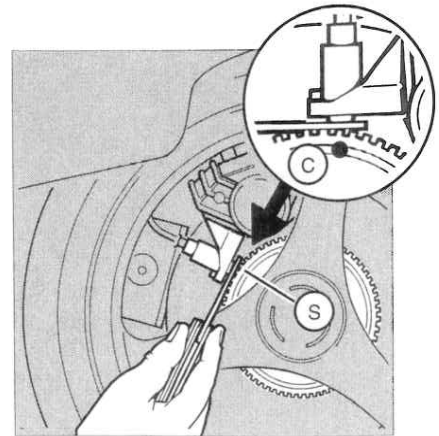
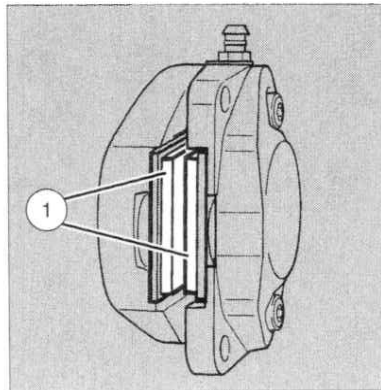
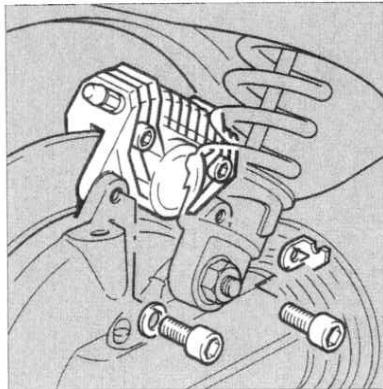

### Rear wheel

#### Tools required

- Allen key
- 8 mm.

#### Procedure

- Place motorcycle on center stand.
- Remove the rear wheel (see page 52).
- Remove the brake caliper (see page 52).
- Check thickness of brake pads (1).  
Minimum pad thickness:  
**1.5 mm (0.06 in)**.
- Install in the reverse order.

#### Tightening torque

- Brake caliper screws (1)  
⇒ **32 Nm (23 ft.lb.)**

#### Note

Have work performed on brake system by your BMW motorcycle dealer or a qualified service technician.

#### Caution

Do not damage brake discs and pads when removing and installing brake calipers!

Do not operate handbrake lever with brake calipers removed!

Ensure brake pads have at least minimum thickness!

Have tightening torques checked by a qualified service technician!

#### Check ABS sensor gap

#### Note

Extreme care must be taken when carrying out this work in order not to interfere with the correct functioning of the system.

#### Caution

After fitting brake caliper, it is essential to check the gap (S) at the point of the maximum distance (chisel punch point "C"), and have it set by your BMW motorcycle dealer or a qualified service technician if necessary.

#### Gap (S)

Rear wheel 0,60 ... 0,65 mm

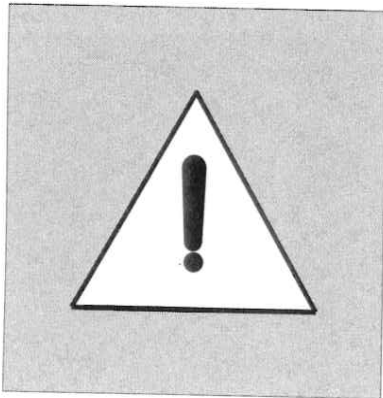

## Electrical system

### Caution

Perform work on the electrical system only when ignition is switched off or battery negative cable disconnected!

Do not touch any live parts when engine is running or there may be a risk of a fatal accident!

### Note

Do not touch new bulbs with your bare fingers.

Use a clean, dry cloth to install.

If touching bulb cannot be avoided, remove finger prints before use.

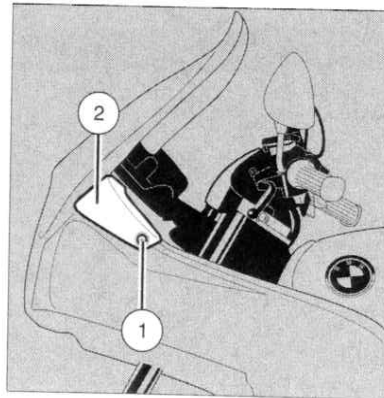

K 75 S

## Renewing front turn-signal bulb

### Tools required

Screwdriver with reversible blade

### Work sequence

- Place motorcycle on centre stand.
- Take out the retaining screw (1).
- Take off the flasher cover (2).
- Release the bulb holder by turning it to the left, and pull it out.
- Press the bulb in and turn it to the left to release it. Take the bulb out.
- Insert the new bulb into the holder, press in and turn to the right to secure.
- Insert the bulb holder in its catch again and secure by turning it to the right.
- Insert the flasher unit and screw it on firmly.

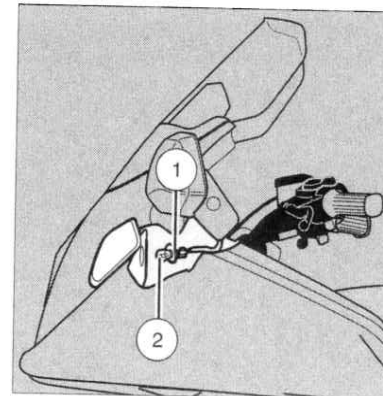

K 75 RT

## Renewing front turn-signal bulb

### Work sequence

Perform removal/installation work from the top. (Reach through between storage compartment, instrument cluster and handlebar.)

- Place motorcycle on centre stand.
- Turn handlebar to left or right.
- Release the bulb holder by turning it to the left, and pull it out.
- Press the bulb (2) in and turn it to the left to release it. Take the bulb out.
- Insert the new bulb (2) into the holder, press in and turn to the right to secure.
- Insert the bulb holder in its catch again and secure by turning it to the right.

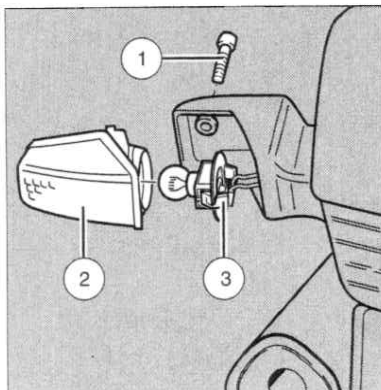

## Renewing flasher bulb, front left/right

### Tools required

Screwdriver with reversible blade

### Work sequence

- Place motorcycle on centre stand.
- Take out retaining screw (1).
- Take out flasher cover (2).
- Press plastic catch (3) to release bulb holder, and remove it.
- Press bulb in and turn to left to release. Take the bulb out.
- Insert new bulb into catch and turn to right to secure.
- Install in the reverse order of work.
- Front/rear indicator bulbs: ⇒ 12V 21W

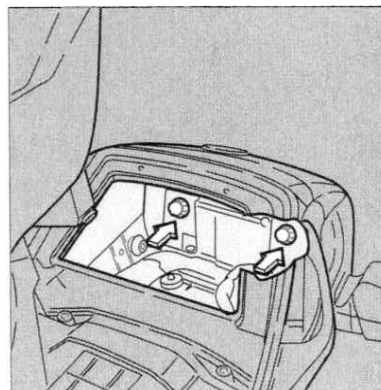

## Renewing rear light bulb and brake light bulb

### No tools required.

### Procedure for removing bulb

- Place motorcycle on center stand.
- Open the dualseat. Remove the cover from the storage compartment.
  - The rear light insert is behind the ABS control unit.
- Reach through under the ABS control unit and take out the two knurled screws (arrow).
- Detach the rear light assembly.
 

Light assembly:	
Top	⇒ brake light
Bottom	⇒ rear light

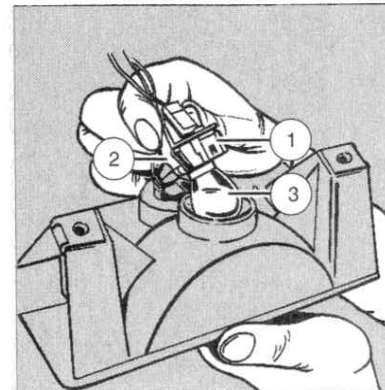

- Remove the bulb insert (1) by pressing in plastic catch (2).
- Press the brake/rear light bulb (3) to the rear (arrow) and release it from its holder by turning it to the left (arrow). Take out the bulb.
- Install in the reverse order of work.
  - Brake light: ⇒ 12V 21W
  - Rear light: ⇒ 12V 10W

### Note

Do not touch new bulbs with your bare fingers.

Use a clean, dry cloth for installing.

If touching bulb cannot be avoided, remove finger prints before use.

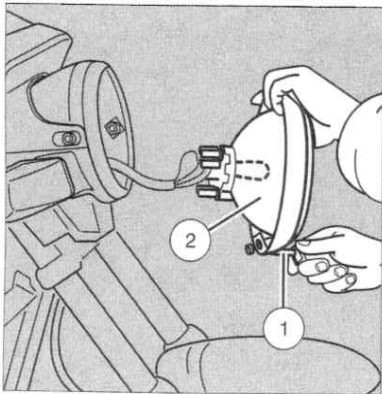

K 75

### Renewing low/high beam headlight bulb or parking light bulb

#### Tools required

Screwdriver with reversible blade

#### Work sequence

Removal/installation work is carried out from the front.

- Place the motorcycle on its centre stand.
- Take out the Phillips-head screw (1).
- Take off the headlight insert (2).
- Renew the low/high beam headlight bulb or the parking light bulb.
- Install bulb in the reverse order.

– Headlight bulb ⇒ **60/55W**

– Parking light bulb ⇒ **12V 4W**

#### Note

Do not touch new bulbs with your bare fingers. Use a clean, dry cloth for installing. If touching bulb cannot be avoided, remove finger prints before use.

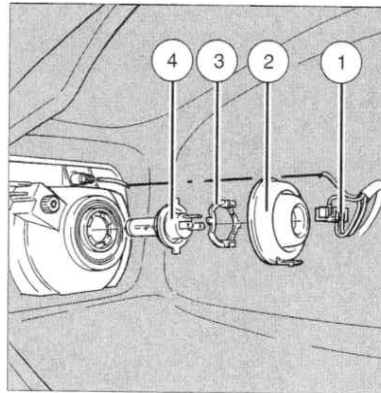

K 75 S, K 75 RT

### Renewing headlight bulb

#### No tools required

#### Procedure for removing bulb

Remove/install bulb through bottom fairing opening.

- Place motorcycle on center stand.
- Take off multiple connector (1).
- Remove rubber seal (2).
- Release locking ring (3) by turning to the left. Remove bulb (4).
- Install bulb in the reverse order.

– Headlight bulb ⇒ **60/55W**

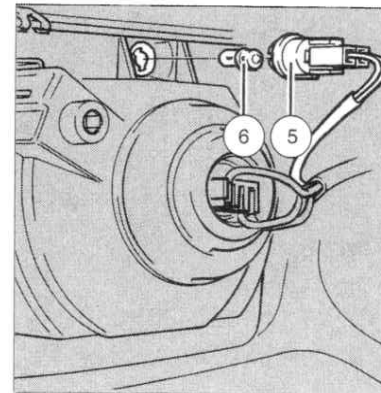

K 75 S, K 75 RT

### Renewing parking light bulb

#### No tools required

#### Procedure

- Place motorcycle on center stand.
  - Release bulb holder (5) by turning to the left.
  - Release bulb (6) by pressing in and turning to the left at the same time.
  - Install bulb in the reverse order.
- Parking light bulb ⇒ **12V 4W**

60

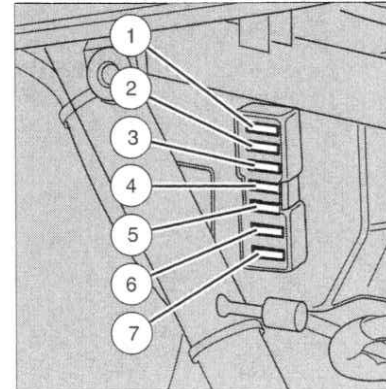
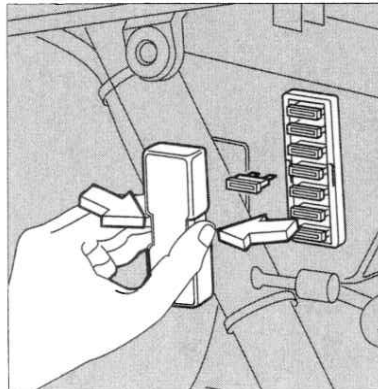
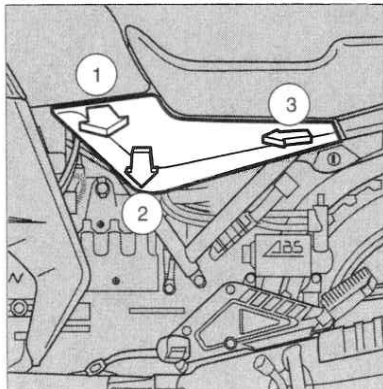

### Renewing fuses

#### No tools required.

#### Procedure

- Place motorcycle on centre stand.
- Take off the battery cover as shown in the drawing.

- Compress transparent cover slightly at the sides (arrows) and withdraw.
- Pull blown fuse out of holder.
- Insert new fuse (spare fuses in tool kit).
- Install parts in the reverse order.

#### Note

Do not repair blown fuses.

If fuse blows frequently, have electrical system checked by your BMW motorcycle dealer or qualified Service technician.

#### Electrical circuits and fuses

#### Fuse assignment:

1 Instrument cluster, rear/brake lights	7,5 A.
2 Parking light	7,5 A.
3 Indicator lights, clock	15 A.
4 Power socket	15 A.
5 Special equipment option	15 A.
6 Fuel pump	7,5 A.
7 Two-tone horns, fan	15 A.

#### Caution

Use only specified fuse types and ratings.

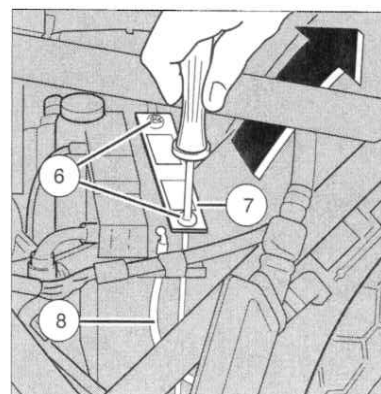
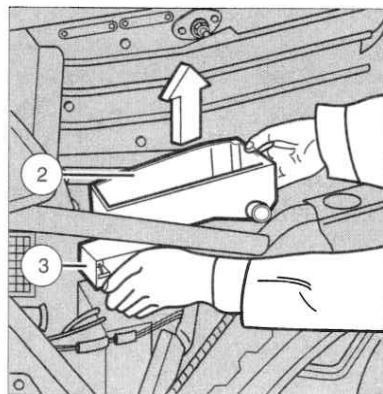
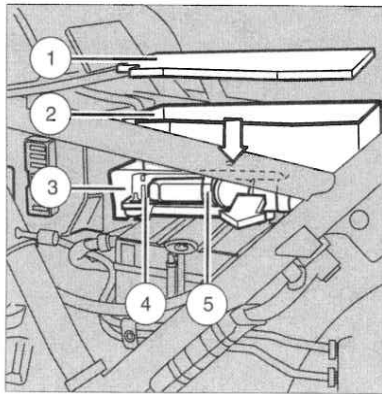

## Removing and installing battery

### Tools required

Allen keys

– 4 mm

Open ended wrench

– 10mm

Screwdriver with reversible blade.

### Procedure for removing battery

- Place motorcycle on center stand.
- **Switch off ignition!**
- Open the dualseat.
- Remove the left-hand battery cover.
- Open the storage tray (2) and take off the cover (1).
- Insert a screwdriver blade through the hole (arrow) in the base of the tray, press it forwards (arrow) and release the catch (4) on the multi-pin plug (5) for the fuel injection control unit (3).

- Pull off the multi-pin plug carefully, release it from the catch and press it to one side.
- Take the storage tray (2) out of the frame together with the fuel injection control unit (3).
- Take out the two Phillips-head screws (6) and remove the battery retaining hoop (7).
- Disconnect battery cables.
  - ⇒ **first of all from negative terminal.**
  - ⇒ **then from positive terminal.**
- Pull battery vent tube (8) out of hole in rear wheel cover.
- Lift out battery to the rear/up the way (arrow).

### Caution

**It is essential to disconnect negative/positive cables in the correct order!**  
**Disconnect battery terminals only when ignition switched off!**

### Procedure for installing battery

- Install bulb in the reverse order.
- Connect battery terminal cables.
  - ⇒ **first positive terminal.**
  - ⇒ **then negative terminal.**
- Grease terminal posts.

### Note

**Do not overtighten the battery holder screws (5).**

### Caution

**Do not kink vent tube (8)!**

**It is essential to connect positive/negative terminal cables in the correct order!**

**Connect battery terminal cables only when ignition switched off!**

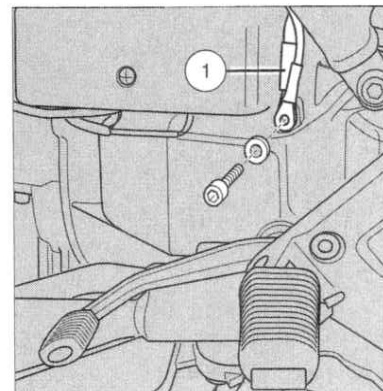
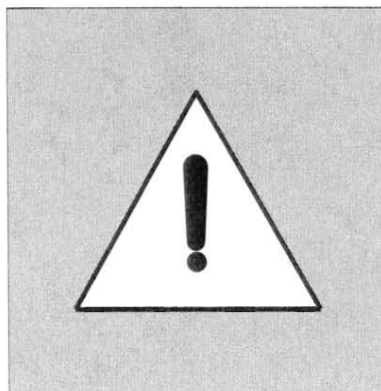
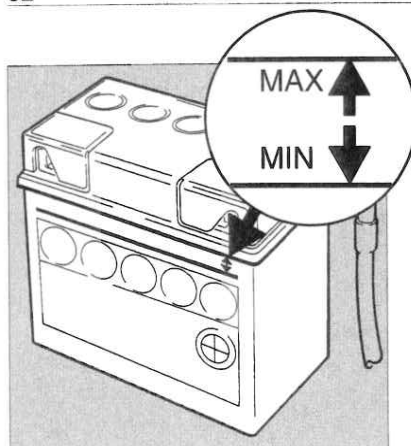

## Checking electrolyte level

### Procedure

- Read off electrolyte level at MIN/MAX markings.

### Note

**Use only distilled water for topping up battery.**

**Remove filler plugs and screw in with a coin.**

### Caution

**Battery acid is corrosive to metal or enamel surfaces.**

**Before recharging or removing a battery, always switch off engine and disconnect the terminals.**

**Never run the engine without the battery connected, or else the alternator may be destroyed.**

**Check that battery venting hose is routed correctly, and open.**

### Warning:

**The battery contains sulfuric acid. Avoid contact with skin, eyes or clothing. Antidote: EXTERNAL-Flush with water, INTERNAL-Drink large quantities of water or milk.**

**Follow with milk of magnesia, beaten egg or vegetable oil.**

**Call physician immediately.**

**Eyes: Flush with water and get prompt medical attention.**

**Batteries produce explosive gases. Keep sparks, flames and cigarettes away. Always shield eyes when working near batteries.**

**KEEP OUT OF REACH OF CHILDREN!**

**Recharge battery only in a well ventilated area.**

**Filler caps must be tight.**

## Maintenance instructions

- If the motorcycle is not ridden for more than a month, disconnect battery terminals.

### Procedure:

**Unscrew the negative cable (1) at the gear box and insulate it.**

- Top up distilled water to MAX mark.
- Store battery in a cool and dry place.
- Check electrolyte level regularly.
- Suggestion: Connect the BMW motorcycle battery charger for 1 day every 4 weeks to maintain optimum battery life.

### Caution

**Always follow instructions for maintaining, charging and storing the battery. This not only battery life, it is also essential for recognition of warranty claims.**

## Troubleshooting table

### Caution

A dangerous or even fatal accident could be caused by touching any live component while the engine is running.

Malfunction	Possible cause	Remedial action	Page
Engine will not start or is difficult to start	Ignition key not in correct position	Refer to operating instructions	41
	Ignition kill switch not turned on	Refer to operating instructions	41
	Power supply interrupted	Fuse 5 blown	60
	Gear engaged, clutch lever not pulled up	Select neutral or disengage clutch	43
	Fuel tank empty	Refuel	28
	Fuel pump not working	Fuse 6 blown	60
	Throttle twistgrip/choke not operating properly	Refer to operating instructions	42
	Air filter element blocked	Renew	
	Spark plug(s) faulty/damp	Renew	
	Spark plug leads/caps damp	Dry with compressed air jet	
Battery insufficiently charged	Charge battery	62	
Coolant temperature too high, warning light remains on all the time (comes on above 115 °C)	Coolant too low	Trace and repair any leaks; add coolant	29
	Electric fan not switching on automatically (at 105 °C)	Fuse 7 blown	60

### Note

Any more serious faults, and other faults not described on pages 45...68, should be entrusted to a BMW motorcycle dealer or qualified service technician for attention.

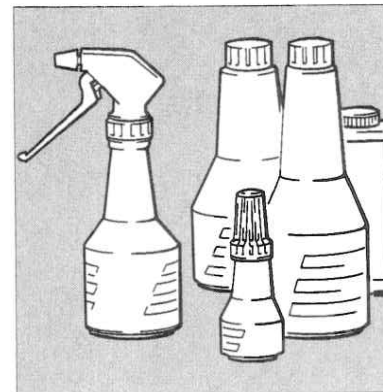
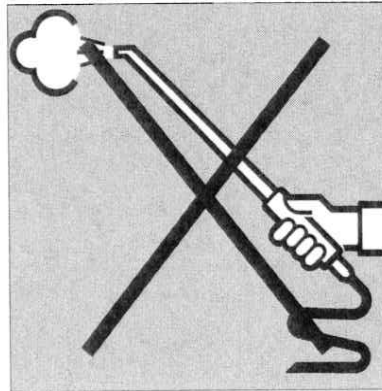
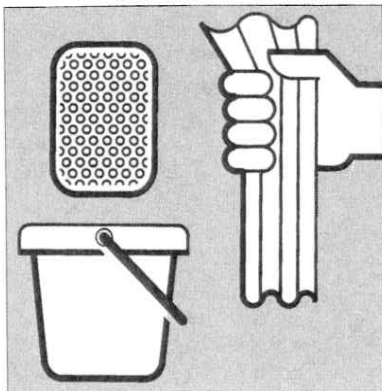

### Cleaning/Care

Most motorcycle owners are familiar with the way an admiring crowd of all ages gathers round a sparkling clean motorcycle whenever it is parked for a few minutes.

Who would not be just a little proud to receive this public recognition of his efforts.

Of course, there are many successful methods of cleaning. Most motorcyclists have devised their own ways of tackling the job.

In view of the problems that can occur even with modern cleaning products and equipment, and the very real risk of damaging the motorcycle or spoiling its appearance, we have compiled a few hints which may be useful.

### Caution

We do not recommend high-pressure water or steam cleaners, because the powerful pressure may damage normal seals at the wheels, etc., may uplift paint damaged by stones and may also penetrate the breather covers at the gearbox and final drive and electrical or electronic equipment and fittings and the hydraulic brake system. The consequences can often be expensive to repair, and may actually cause a safety hazard.

- A better approach: spray very dirty areas, e.g. wheels and transmission, with an approved mild-action engine or cold cleaner, allow this to soak in for the period of time specified by the supplier and then wash it off with a mild spraying water jet. Place the motorcycle on the side stand so that the motorcycle is tilted to the left to drain water from the top of the engine. Finally, dry thoroughly.

- After washing the motorcycle down in this way, it is advisable to test the brakes.
- Rubber and plastic components, particularly flashing turn indicators, rear light, instrument cluster, switches, etc., must be protected against cleansers and solvents.
- Wash paintwork with a mild, non alkaline dishwashing liquid and plenty of clean water, using a clean sponge or wash-leather. Remove dead insects in the same way.
- Clean/care for fairing sections only with approved BMW cleaning/care products. Do not scratch windscreen.
- Remove tar stains only with approved removers. Rinse down thoroughly afterwards.
- Treat chrome parts and paintwork regularly with suitable approved BMW care products.

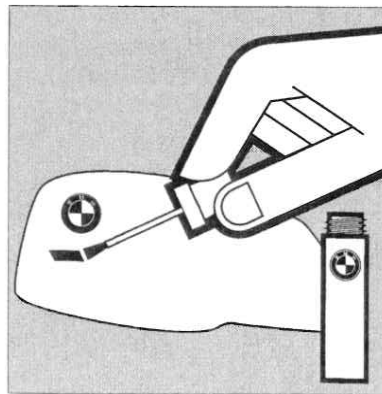
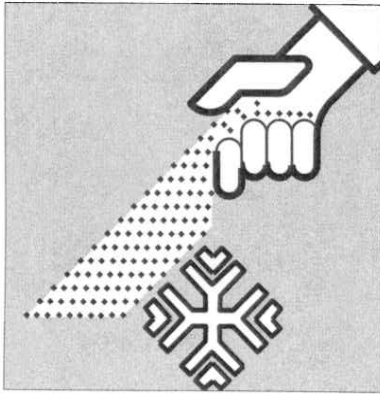

#### Removing road salt

- Clean motorcycle at the end of your ride immediately with cold water.  
⇒ **Do not use warm water as this increases the chemical action of the salt!**
- Dry motorcycle thoroughly.
- Use a commercial wax-based corrosion proofing agent to treat rims, engine, swing arms and chrome parts.
- Rub/polish cleaned and dried fairing sections with an approved wax product.

#### Caution

**Do not use steam cleaners or high pressure jets!**

#### Touching up paint damage

- Touch up minor paint damage caused by flying stones or similar with BMW Touch Up Stick.  
⇒ **Paint color indicated on decal below dualseat.**  
⇒ **Pay attention to manufacturer's instructions for use.**
- Have major damage to paintwork attended to by your BMW motorcycle dealer.
- Only through proper care will your motorcycle finish be maintained. Avoid prolonged exposure to sunlight or your paint finish may fade or be damaged eventually. Cover your motorcycle when not in use.

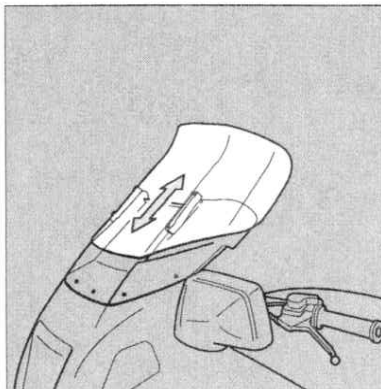

K 75 RT

#### check the windshield

##### Warning:

**Check mounting hardware periodically. A loose mount places undue stress on the windshield and could possibly result in premature failure.**

**Never ride your motorcycle with loose or missing windshield mounting hardware. Check the hardware tightness regularly.**

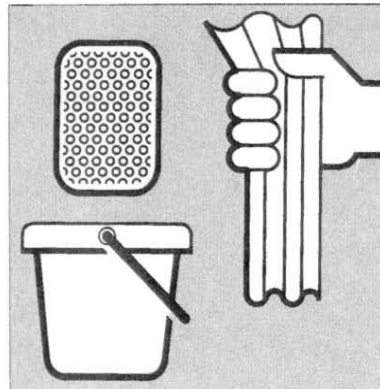

#### Care and cleaning windshield

Your windshield is made of prime G.E. Lexan<sup>®</sup> FMR hardcoated polycarbonate sheet. Always pre-rinse screen with water to remove grit and soften dirt. Wash with mild liquid soap, lots of warm water, and a clean soft cloth or sponge. Rinse well to remove all soap residue. Dry with a chamois, flannel or moist sponge to prevent water spots. Paint, grease; Use a cotton ball moistened with turpentine, follow with wash as described above. This also works on label residue.

If a hairline scratch or abrasion occurs on your windshield it can be minimized with a non-silicone polish. The polish will make cleaning easier and fill scratches, making them invisible. Recommended products:

- Meguiar's Mirror Glaze Professional Plastic Cleaner #17 BMW P/N 88 88 2 000 003
- Meguiar's Mirror Glaze Professional Plastic Polish #17 BMW P/N 88 88 2 000 004

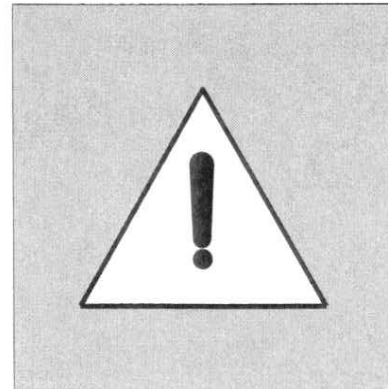

#### Caution

**Do not clean Lexan<sup>®</sup> hardcoated polycarbonate in hot sun or high temperature. Powered, abrasive, or alkaline cleaners will damage the windshield. Never scrape the windshield with a razor blade or other sharp instrument as permanent damage will result.**

**Your BMW windshield is constructed from surface-hardcoated polycarbonate sheet which may not be compatible with certain cleaning or rain-shedding products, particularly (but not limited to) those of acidic origin. These products can penetrate the hardcoating, particularly around the edges and areas of stress (sharply formed bends) creating foggy or glare spots. Damage resulting from these products is not covered under the BMW Limited Warranties.**

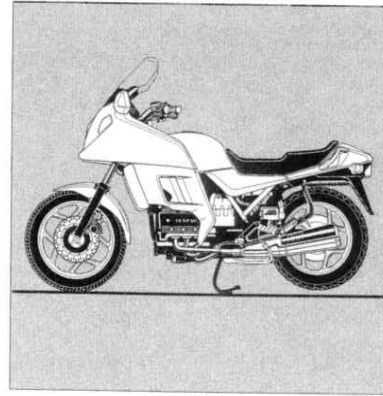
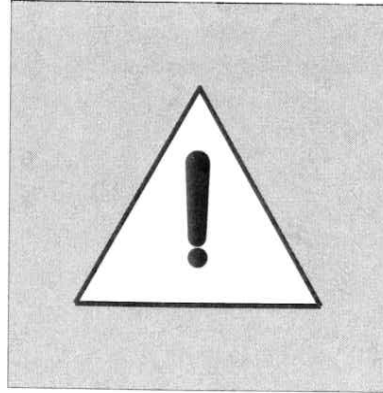
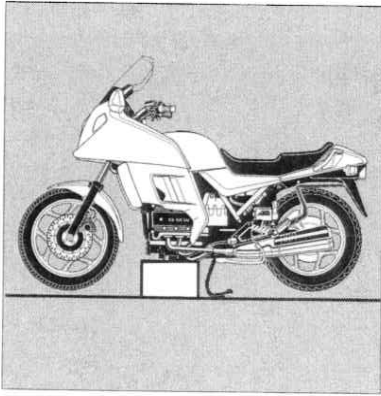

## Storing motorcycle

### Procedure

- Clean motorcycle (see page 64).
- Remove battery (see page 61). Pay attention to maintenance instructions (see page 62)!
- Lubricate brake pedal and clutch lever joints, center and side stand bearings.
- Spray bright metal/chrome parts S 100 Corrosion Protectant.
- Store motorcycle in a dry room on center stand.
- Place block under the engine so that both wheels are off the ground.

### Note

**Before the motorcycle is laid up out of use, ask your BMW motorcycle dealer to change the engine oil and renew the oil filter element.**

**Work needed in connection with laying up the motorcycle or restoring it to the road is best combined with an Inspection or Oil Service performed by the BMW motorcycle dealer.**

## Restoring motorcycle to use

### Procedure

- Remove protective coatings applied to exterior.
- Clean motorcycle (see page 64).
- Install fully-charged battery (see page 61).
- Treat battery terminal posts and clips with protective grease.
- Check/correct tire inflation pressure (see page 33).
- Check brakes (see pages 30-32).
- Perform safety checks (see pages 25-36).

# Specifications

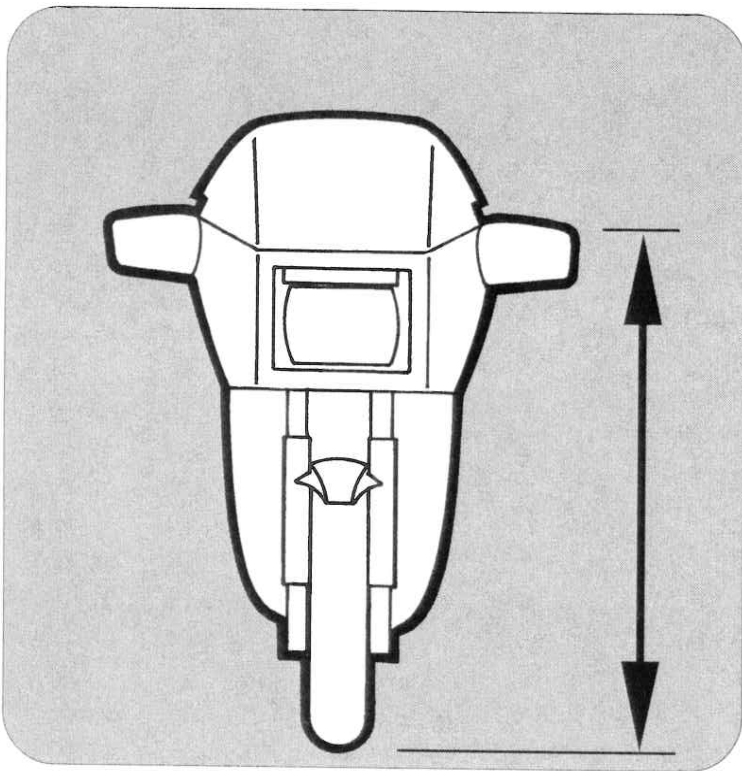

## And just as important:

### Technical data and descriptions

- Engine (70)
- Power transmission (71)
- Frame (72, 73)
- Fuels, lubricants etc. (74, 75)
- Electrical systems (76)
- Dimensions (77)
- Weights (78)

( ) Figure in brackets ⇒ Page on which item is described.

70

## Technical data and descriptions

Engine		K 75	K 75 S	K 75 RT
Type		Patented, longitudinal inline flat-three, compact four-stroke engine with two overhead camshafts, water cooling, electronic fuel injection, overrun fuel shutoff and a microprocessor-controlled digital ignition system.		
Displacement	ccm	740		
Max. permissible engine speed	rpm	8700		
Max. continuous engine speed	rpm	8600		
Idle speed	rpm	950 +/- 50		
Bore/stroke	mm	67/70		
Compression ratio		11.0:1		
Type of fuel		Unleaded middle or premium grade fuel, minimum octane number 89 (Anti Knock Index $(R+M)/2$ ) or minimum octane number 95 (RM) and 85 (MM).		



Transmission	K 75	K 75 S	K 75 RT
<b>Clutch</b>	Single dry plate, mounted on output shaft and revolving in opposite direction to crankshaft, with lever-action disc spring, aluminium forged flywheel and asbestos-free clutch linings; responsive mechanical release action with low release forces, clutch lever force approx. 70 N.		
Clutch plate $\varnothing$	mm (in)	165 (6.5)	
<b>Gear box</b>	Constant-mesh 5-speed gearbox with integral shock-absorber and weight-reducing aluminium components.		
Gear ratios		1st = 4.50 2nd = 2.96 3rd = 2.30 4th = 1.88 5th = 1.67	
<b>Power transmission from gearbox to rear wheel</b>	New type of propeller shaft with torsional vibration damper housed in swinging arm (BMW "monolever"); arm pivot aligned with universal joint axis to avoid changes in shaft length. At both ends, drive through flank-centred involute splines.		
<b>Rear wheel drive</b>	Crown wheel and bevel pinion with palloid gear pattern running in antifriction bearings, with rear wheel attached directly to flange formed on back of crown wheel. Integral castelated ring and inductive transmitter supply ratio-independent pulses to electronic speedometer.		
Final drive ratio (Standard version)		3,20 : 1	
Number of teeth		32/10	

Frame and suspension	K 75	K 75 S	K 75 RT
<b>Frame</b>	Single-section torsionally rigid lattice tube frame enclosing engine and gear box assembly as stressed element; <b>not approved for sidecar or trailer attachment.</b>		
Location of Vehicle Identification Number (V.I.N.)	On rear right frame tube strut.		
<b>Suspension</b>			
Front	Long-stroke responsive telescopic fork with travel dependent hydraulic dampers and progressive spring rates.		
Total spring travel	mm (in)	135 (5.31)	
Stanchion diameter	mm (in)	41.4 (1.63)	
Rear	Swinging arm (BMW "monolever") made from a high-strength light alloy, with a single suspension strut (progressive-rate coil spring and double-acting gas-filled telescopic damper); three-position setting to suit varying loads.		
Total spring travel (at wheel)	mm (in)	114 (4.49)	
Swing arm length	mm (in)	400 (15.7)	
<b>Max lock angle of front wheel</b>	2 x 40°	2 x 35°	2 x 34°
<b>Front wheel caster</b>			
At unladen weight	mm (in)	101 (3.98)	
In normal-load position with 75 kg (165 lbs) rider	mm (in)	105 (4.13)	
<b>Front wheel brake</b>	Hydraulic, twin disc, with slotted stainless-steel brake discs and two fixed calipers with semi-metallic brake pads.		
<b>Rear wheel brake</b>	Part-integrated hydraulic disc brake.		

**Frame and suspension**

		K 75	K 75 S	K 75 RT
<b>Wheels and tires</b>		BMW cast light alloy wheels of Y-spoke design, and H-profile pattern		
<b>Front wheel</b>		with inclined shoulder rim and double hump		
Size and designation		2.50 x 18 MT H2		
Tire size and designation		100/90 - 18 56V TUBELESS		
<b>Rear wheel</b>		with inclined shoulder rim and double hump		
Size and designation		2.75 x 17 MT H2		
Tire size and designation		130/90 - 17 68V TUBELESS		
<b>Tire pressures</b> with cold tires				
One-up	front	bar (p.s.i.)	2.2	(31.9)
	rear	bar (p.s.i.)	2.5	(36.3)
Two-up	front	bar (p.s.i.)	2.5	(36.3)
	rear	bar (p.s.i.)	2.9	(42.0)
<b>Tire tread depth</b> (minimum recommendation)				
Front wheel		mm (in)	2	(0.079)
Rear wheel		mm (in)	3	(0.118)

Note legal requirements concerning minimum tread depth.

**Oils and lubricants**

K 75

K 75 S

K 75 RT

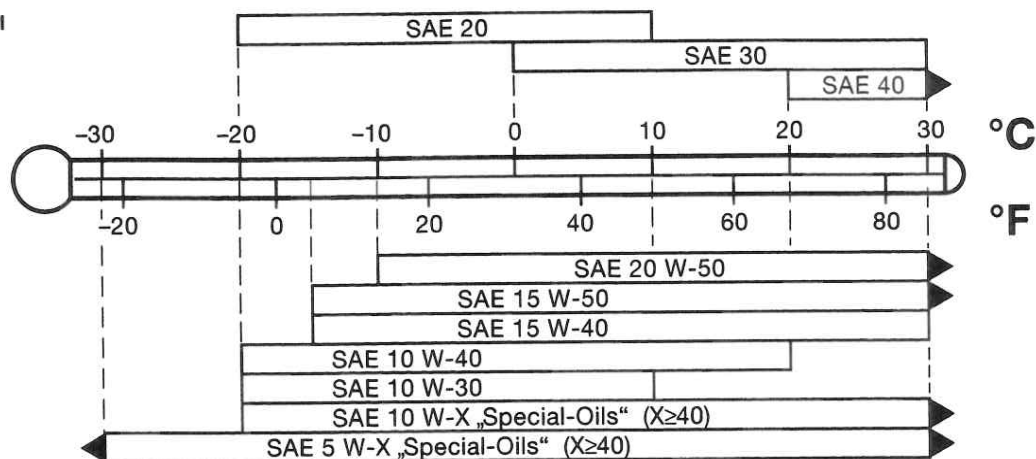
**Engine oil**

Brand HD oil for with API classification SF, SG or SH; extensions CD and CE are permitted; or brand HD oil with CCMC classification G4 or G5; extension PD2 is permitted.

Viscosity class depending on outside temperature.

The temperature limits of SAE classes can be exceeded or undercut for short periods.

The "special oils" are approved in name by BMW AG and available from your BMW motorcycle dealer. All engine oils sold by BMW are subjected to permanent BMW quality control.

Oil additives of all kinds are rejected by the manufacturer.

**Engine oil content**

without filter renewal	l	3.50
if filter is renewed	l	3.75

Oils and lubricants		K 75	K 75 S	K 75 RT
<b>Gear oil</b>		Proprietary Hypoid gear oil, API Class GL 5		
Gearbox capacity	l (fl.oz.)	0.8	(27.00)	
Rear wheel drive capacity	l (fl.oz.)	0.25	(8.45)	
<b>Viscosity class at outside temperature</b>				
above 5 °C	SAE	90		
below 5 °C	SAE	80		
Alternatively	SAE	80 W 90		
<b>Telescopic fork oil – approved grades</b>		Esso Comfort		
Content per fork leg				
Refilling after dismantling	cc (fl.oz.)	420	(14.00)	
After oil change	cc (fl.oz.)	410	(13.67)	
<b>Steering bearing lubrication and other lubrication points</b>		Proprietary anti-friction grease, useful temperature range 30 °C...+140 °C, pour point 150 °C...230 °C, high corrosion protection, good water/oxidation resistance; e.g. Shell Retinax A.		
<b>Battery terminal posts – oxidation protection</b>		Acid-free grease, e.g. Vaseline		
<b>Brake fluid</b>		BMW DOT 4, ATE "SL" DOT 4, Castrol Disc Brake, DOW ET 504 Shell Donax DOT 4, Hydraulan DOT 4		
<b>Engine coolant</b>		BMW Anti-Freeze/coolant or proprietary longlife antifreeze and corrosion inhibitor.		
		<b>Caution</b>		
		<b>Use only antifreeze and corrosion inhibitors free of nitrite!</b>		
Capacity	l (qts.)	3 + 0,4 (3.17 + 0.42) (in expansion tank)		

Electrical system		K 75	K 75 S	K 75 RT
<b>Battery</b>		12V BMW-Mareg, with transparent polypropylene casing		
Voltage/capacity	V/Ah	12/25 (standard version)		
<b>Ignition timing</b> (full load)	°CS	6...31 (advance)		
<b>Spark plugs</b>		M 12 x 1.25 thread		
Approved makes and types		Bosch XR 5 DC, Beru 12R-5 DU		
Electrode gap	mm (in)	0.6 + 0.1 (0.024 + 0.004)		
Maximum Electrode Gap	mm (in)	0.9 (0.035)		
<b>Circuit protection</b>		"Minifuse" (flatpin) fuses, 7 circuits		
Load rating	A	7,5	(3 circuits)	
	A	15	(4 circuits)	
<b>Headlight</b>		180Ø	170 x 110	200 x 130
<b>Bulb</b>				
Headlight high/dipped beam		H4 Halogen 12V 60/55W, asymmetric dipped beam		
Parking light	DIN 72601	12V 4W, standard designation T/4		
Rear light: Tail light	DIN 72601	12V 10WE, standard designation R 19/10		
Brake light	DIN 72601	12V 21W, standard designation P 25-1		
Turn signal lights	DIN 72601	12V 21W (4x), standard designation P 25-1		
Turn signal telltale lights	DIN 72601	12V 4W (2x), standard designation T 8/4		
Other telltale lights and instrument lighting	DIN 72601	12V 3W (13x), standard designation W 10/3		

<b>Dimensions</b>		<b>K 75</b>		<b>K 75 S</b>		<b>K 75 RT</b>	
Overall length	mm (in)	2220	(87.40)			2230	(87.80)
Width over mirrors	mm (in)	900	(35.43)	810	(31.89)	916	(36.06)
Width over handlebars (with weights)	mm (in)	710	(27.95)	650	(25.59)	770	(30.31)
Width over rider's footrests	mm (in)	620	(24.40)				
Width over pillion footrests	mm (in)	675	(26.57)				
Max. height (excl. mirrors)	mm (in)	1300	(51.18)	1340	(52.76)	1460	(57.48)
Seat height at unladen weight	mm (in)	760/800	(29.92/31.49)	810	(31.89)	810	(31.89)
<b>Wheel base</b>							
At unladen weight	mm (in)	1516	59.69				
In normal-load position with 75 kg (165 lbs) rider	mm (in)	1511	(59.49)				
<b>Ground clearance</b>							
At unladen weight	mm (in)	175	(6.89)				
In normal-load position	mm (in)	150	(5.91)				
Turning circle	m (ft)	5,1	(16.72)	5,4	(17.70)	5,1	(16.72)

<b>Weights</b>		<b>K 75</b>		<b>K 75 S</b>		<b>K 75 RT</b>	
Dry weight (without fuel, coolant, lubricant, tools)	kg (lbs)	204	(450)	211	(465)	234	(515)
Unladen weight (ready for road, with full tank)	kg (lbs)	228	(502)	235	(518)	258	(564)
Gross weight limit	kg (lbs)	480	(1057)				
<b>Wheel load limits</b>							
Front	kg (lbs)	200	(441)				
Rear	kg (lbs)	315	(694)				
<b>Axle load distribution front/rear</b>							

# Alphabetical Index

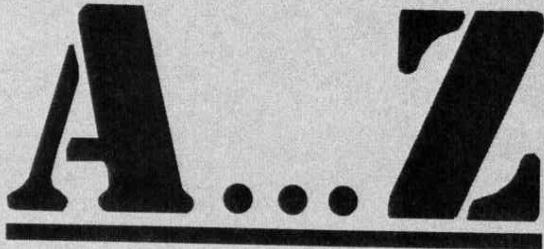

80

- A**dding fuel, 28
- Alternator, Warning light, 40
- Antilock Braking System (ABS)
  - Acting and operating
    - Cancel switch, 22
    - General Operation, 22
    - Important notes, 23
  - Check sensor gap, front, 50
  - Check sensor gap, rear, 53, 56
  - Notes on operating, 21
  - What ABS Means on the Road, 20
- Axle load distribution, 78
- B**attery
  - Checking electrolyte level, 62
  - Maintenance instructions, 62
  - Removing/installing, 61-68
  - Voltage/capacity, 76
- Before starting the engine, 41
- BMW**
  - Cleaning/care products, 24
  - Parts and Accessories, 47
- Bore/stroke, 70
- Brake**
  - Checking brake pads
    - Front wheel, 55
    - Rear wheel, 56
  - Fluid, 75
  - Fluid level
    - front/rear, 30
    - Topping up, 31
  - Handbrake lever travel, 32
  - Pedal travel, 32
  - Test before starting, 30
- Breaking-in rules, 39
- Bulbs**
  - Headlight, 59
  - Parking light, 59
  - Technical data, 76
  - Turn-signal, 57, 58
- C**are and maintenance, 46
  - Checking brake pads, 55-56
  - Check ABS sensor gap, 56
  - Cleaning/Care, 64-68
    - Exhaust system, 65
    - Removing road salt, 65
    - Touching up paint damage, 65
  - Correcting coolant level, 29-36
  - Electrical system
    - Adjusting headlight beam angle, 36
    - Checking electrolyte level, 62-68
    - For countries with leftside rule of the road, 36
    - Removing/installing battery, 61-68
  - Renewing bulbs
    - Headlight, 59
    - Parking light, 59
    - Turn-signal, front, 57
    - Turn-signal, rear, 58
  - Renewing fuses, 60
  - General notes, 46
  - Original BMW
  - Parts and Accessories, 47
  - Removing/installing front wheel, 49-52
    - Check ABS sensor gap, 50
    - Tightening torques, 51
  - Removing/installing rear wheel, 52-54
    - Check ABS sensor gap, 53
    - Tightening torques, 54
  - Repair kit for tubeless tires, 48
  - Restoring motorcycle, 67
  - Storing motorcycle, 67
  - Technical Modifications, 47
  - Tool kit, 48
  - Topping up brake fluid, 31-36
  - Troubleshooting table, 63-68
- Catalytic converter, 38
- Center stand, 44
- Changing gears, 43
- Choke**
  - Operating, 42
  - Resetting, 42
- Circuit protection, Load rating, 76
- Cleaning/Care, 64-68
  - High-pressure water cleaner, 64, 67
- Clutch, 71
  - Lever travel, 32
  - Plate XX, 71
- Compression ratio, 70
- Continuous engine speed, 70
- Coolant**
  - Capacity, 75
  - Correcting level, 29
  - Level, 29
  - Mixing ratio, 29
- Coolant temperature gauge, 40
- D**imensions, 77
- Displacement, 70
- Dry weight, 78
- Dualseat lock, 19
- E**lectrical system
  - Battery**
    - Checking electrolyte level, 62
    - Maintenance instructions, 62
    - Removing/installing, 61-68
  - Fuses, Renewing, 60
  - Headlight beam
    - Adjusting, 36
    - Aiming, 36
  - Renewing bulbs
    - Headlight, 59
    - Parking light, 59
    - Turn-signal, 58
  - Technical data, 76
    - Battery, 76
    - Blubs, 76
    - Circuit protection, 76
    - Headlight, 76
    - Ignition timing, 76
    - Spark plugs, 76
  - Electrode gap, 76
  - Electrolyte level, 62
  - Engine
    - Coolant, 75
    - Capacity, 75
    - Oil pressure, 27

- Speed limits, 39
- Starting, 41
- Technical data, 70
  - Bore/stroke, 70
  - Compression ratio, 70
  - Displacement, 70
  - Engine speed, 70
  - Idle speed, 70
  - Type, 70
  - Type of fuel, 70
- Engine oil, Level, 27
- Exhaust system, 65
- Final drive ratio, 71**
- Frame and suspension, 72
- Front wheel, Size and designation, 73
- Front wheel caster, 72
- Fuel
  - Adding, 28
  - Gauge, 14, 28
  - Level, 13, 28
  - Type of, 28, 70
- Fuses, 76
  - Renewing, 60
- Gear display, 41**
- Gearbox, 71
  - Gear ratios, 71
  - Oil capacity, 75
  - Power transmission, 71
- Gears, Changing
  - Shifting down, 43
  - Shifting up, 43
- Gross weight, 78
- Ground clearance, 77
- Handlebar controls, 15**
- Hazard warning flashers, 16
- Headlight, Bulb, 59, 76
- Headlight beam
  - Adjusting, 36
  - Leftside rule of the road, 36
- Heated handlebar grips, 16
- Height, max., 77
- High performance ignition system, 26
- High-pressure water cleaner, 64, 67
- Horn control, 15
- Idle speed, 70**
- Ignition
  - Kill switch, 15
  - /steering lock, 12
  - Switching on, 41
- Ignition timing, 76
- Important Safety Information, 4
- Instrument unit, 13
- Keys, 12**
- LCD Digital clock, 17**
- Length, overall, 77
- Lights, 35
- Loads, 35
  - Axel, 78
  - Wheels, 78
- Lock angle, front wheel, 72
- Odometer, 13**
- Oil
  - Approved grades, 74
  - Capacity
    - Engine, 74
    - Gearbox, 75
    - Rear wheel drive, 75
    - Telescopic fork, 75
  - Checking, Engine, 27
  - Pressure, 27
  - Viscosities, 74
- Operating choke, 42
- Operating instructions
  - Adding fuel, 28
  - Antilock Braking System (ABS)
    - Notes on operating, 21
    - What ABS Means on the Road, 20
  - Dualseat lock, 19
  - Fuel gauge, 14
  - Handlebar controls, 15
  - Hazard warning flashers, 16
  - Heated handlebar grips, 16
- Ignition and steering lock, 12
- Instrument unit, 13
- Keys to motorcycle, 12
- LCD Digital clock, 12
- Temperature gauge, 14
- Turn-signals (self cancelling), 15
- Original BMW Parts and Accessories, 47
- Paint damage, 65**
- Parking light bulb, 59, 76
- Permissible engine speed, 70
- Permissible gross weight, 35
- Power sockets, 17
- Power transmission, 71
- Radio, 18**
- Reading lamp, 18
- Rear light, Telltale, 40
- Rear light bulb, 76
- Rear wheel, Size and designation, 73
- Rear wheel drive, 71
  - Final drive ratio, 71
  - Number of teeth, 71
  - Oil capacity, 75
- Repair kit (tires), 48
- Reporting Safety Defects, Inside front cover
- Restoring motorcycle, 67
- Rims, Safety check, 33
- Road salt, 65
- Safety checks**
  - Brake fluid level, 30
  - Brake pedal travel, 32
  - Clutch lever travel, 32
  - Coolant level, 29
  - Engine oil level, 27
  - Fuel level, 28
  - General note, 26
  - Handbrake lever travel, 32
  - High performance ignition system, 26
  - Lights, 35
  - Loads, 35
  - Rims/wave caps, 33
  - Side stand, 34

- Spring strut preload, 34
- Tire pressures, 33
- Tread depth, 33
- Safety Information, 4
- Seat height, 77
- Selecting neutral, 41
- Side cases, Maximum speed, 35
- Side stand, 34, 44
- Spark plugs
  - Approved makes and types, 76
  - Electrode gap, 76
- Speedometer, 13
- Spring strut preload, 34
- Spring travel, front/rear, 72
- Stanchion diameter, 72
- Starter switch, 42
- Starting the engine, 41
- Starting-Riding-Parking
  - Before starting the engine, 41
  - Breaking-in rules, 39
  - Catalytic converter, 38
  - Changing gears, 43
  - Charge current/Alternator, 40
  - Coolant temperature gauge, 40
  - Engine oil pressure, 27
  - Engine speed limits, 39
  - Operating choke, 42
  - Placing motorcycle
    - Center stand, 44
    - Side stand, 44
  - Pressing starter switch, 42
  - Rear light telltale, 40
  - Resetting choke, 42
  - Selecting neutral, 41
  - Switching on ignition, 41
- Storage compartments, 19
- Storing motorcycle, 67
- Stroke, 70
- Swing arm length, 72
- Switch
  - Horn control, 15
  - Ignition kill, 15
  - Starter, 15, 42
- Turn-signal, 15
- Turn-signal cancel, 15
- Switching on Ignition, 41
- Technical data and description**
  - Dimensions, 77
  - Engine, 70-78
  - Frame and suspension
    - Caster, front wheel, 72
    - Lock angle, front wheel, 72
    - Spring travel, front/rear, 72
    - Stanchion diameter, 72
    - Swing arm length, 72
    - Vehicle Identification Number, 72
    - Wheels and tires, 73
  - Oil and lubricants, 74
  - Transmission
    - Clutch, 71
    - Gearbox, 71
    - Rear wheel drive, 71
  - Weights, 78
- Technical Modifications, 47
- Telescopic fork, Oil capacity, 75
- Telltale
  - ABS, 13, 40
  - High beam, 13
  - Neutral/gearbox, 13, 41
  - Rear light monitor, 13, 35, 40
  - Turn-signal, 13
- Telltale lights bulb, 76
- Temperature gauge, 14
- Tightening torques
  - Brake caliper screw, 55, 56
  - Front wheel, 51
  - Rear wheel, 54
- Tilt angle, 77
- Tire
  - Pressure, 33, 73
  - Repair kit, 48
  - Size and designation, 73
  - Tread depth, 33, 73
- Tool kit, 48
- Transmission
  - Clutch, 71
- Gearbox, 71
- Rear wheel drive, 71
- Tread depth, 33
- Trip odometer, 13
- Troubleshooting table, 63
- Turn-signal, Bulb, 76
- Turn-signal
  - Bulb, 57
  - Cancel switch, 15
  - Self cancelling, 15
  - Switch, 15
  - Telltale, 13
- Turning circle, 77
- Unladen weight, 78**
- Valve caps, 33**
- Vehicle Identification Number, 72
- Warning light**
  - ABS, 13, 22
  - Alternator, 13, 40
  - Coolant temperature, 13, 29
  - Engine oil pressure, 13, 27
  - Fuel level, 13
- Weights, 78
- Wheel
  - Caster, front, 72
  - Load limits, 78
  - Lock angle, front, 72
  - Removing/installing, front, 49
  - Removing/installing, rear, 52
  - Safety check, 33
  - Size and designation, 73
- Wheel base, 77
- Width
  - over handlebars, 77
  - over mirrors, 77
  - over pillion footrests, 77
  - over rider's footrests, 77
- Windshield
  - Care and cleaning, 66
  - checking, 66
- Windshield adjusting, 18

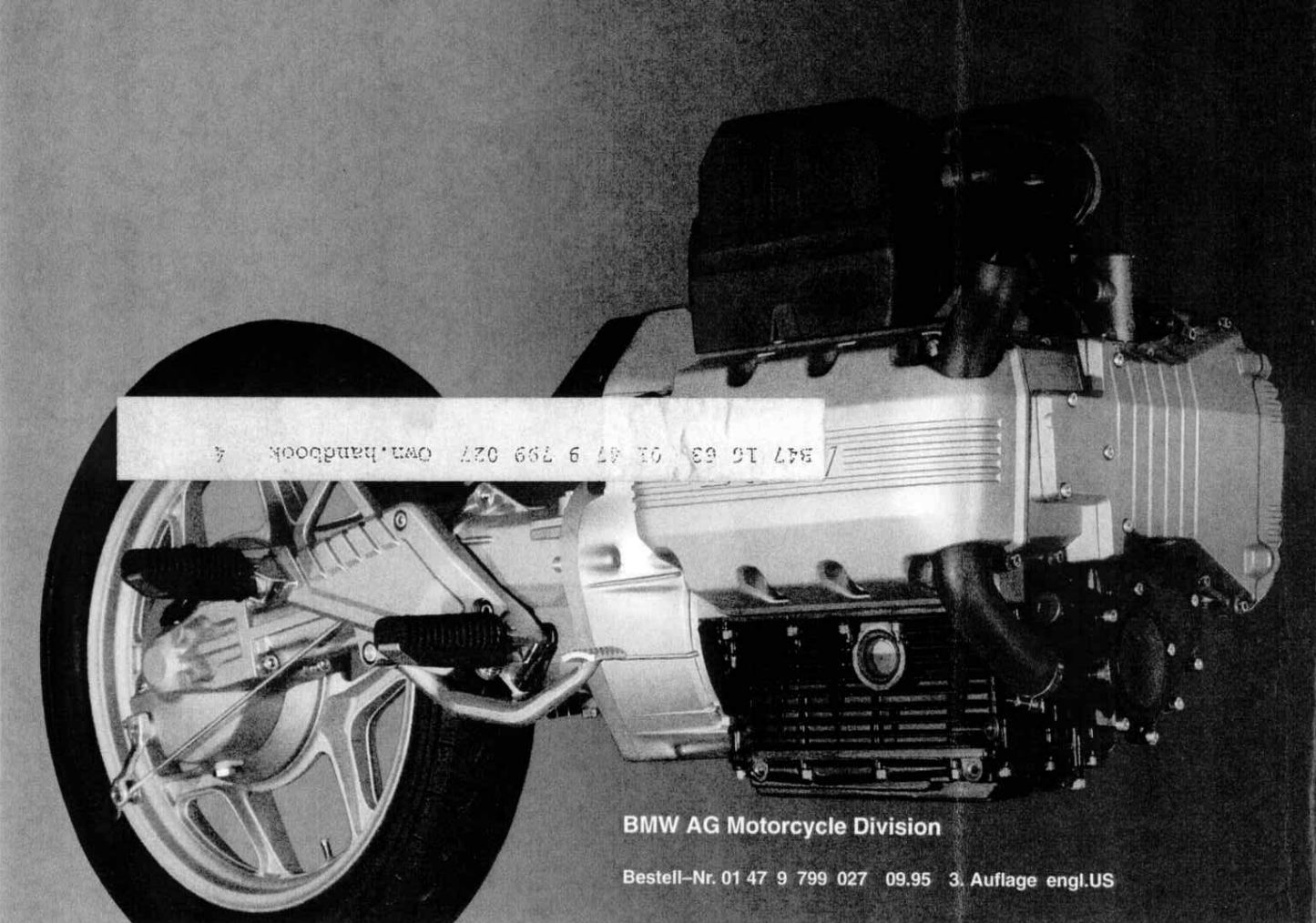

**BMW AG Motorcycle Division**

Bestell-Nr. 01 47 9 799 027 09.95 3. Auflage engl.US