

## Coolant level

### Checking

- Engine cold.
- Place motorcycle on center stand.
- Remove the battery cover on the right.
- Read off coolant level at expansion tank (arrow).
- Add coolant, if necessary, up to bottom of filler neck.

### Caution

If the coolant temperature warning lamp (red) comes on, check coolant level in expansion tank immediately (see above).

## Correcting coolant level

### Procedure

- Place motorcycle on center stand.
- Take off the right battery cover (see page 70).
- Remove the filler cap.
- Top up with coolant mixture as far as the "MAX" mark.
- Put the filler cap back on.

### Caution

If expansion tank is full and warning lamp is still on or you have excessive coolant consumption, contact your BMW motorcycle dealer or qualified service technician. Operation with an overheated engine may cause damage to the engine.

### Note

Correct coolant level only when engine is cold.

Refill at expansion tank when there is a slight loss of coolant.

### Mixing ratio:

40% antifreeze,  
60% water.

Provides antifreeze protection down to:  
- 26 °C (- 8 °F)

Have coolant replaced every two years regardless of mileage.

Nitrite-free BMW Coolant is available from your authorized BMW motorcycle dealer.

### Caution

Use only antifreeze and anti-corrosion agents free of nitrite!

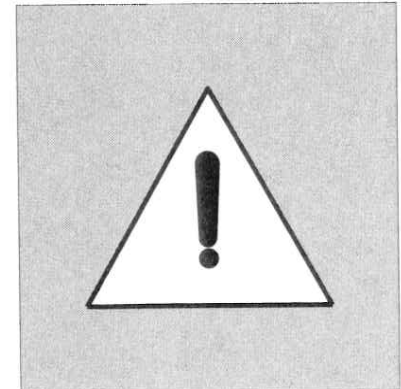
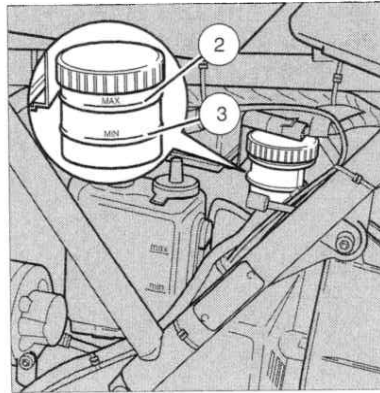
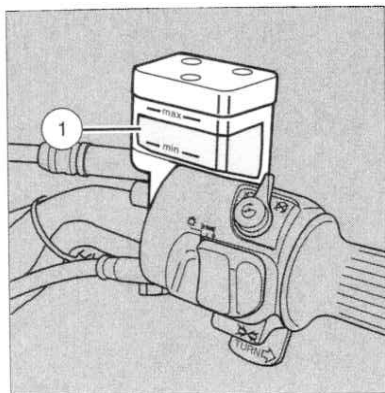

## Brake fluid level

### Checking: Front wheel brake

- Turn steering to left.
- Check brake fluid level at transparent reservoir (1).
- Note "MIN/MAX" marks.
- If necessary, add brake fluid up to "MAX" mark (see page 31).

### Caution

Do not allow fluid to drop below Minimum level!! Fluid must be visible in sight glass!

### Checking: Rear wheel brake

- Remove the right battery cover.
- Take reading of brake fluid level at MAX/ MIN markings.
- **Maximum level (2)**
- **Minimum level (3)**
- Top up brake fluid up to MAX marking, if necessary. Refer to page 31 for topping up.

### Caution

Do not allow fluid to drop below Minimum level!

## Brakes

Before starting any trip, always test the brakes:

- the hydraulic brake circuit is intact if the brake lever can be operated without a 'spongy' feeling.
- there must be sufficient brake fluid in the front reservoir.
- brake discs and calipers must be free from oil, grease and traces of solvents or cleansers.

### Warning:

Never ride your motorcycle if you are in any doubt as to the condition of the brakes.

Check with your BMW motorcycle dealer or qualified service technician immediately.

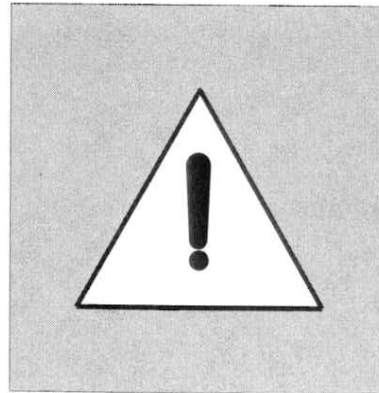
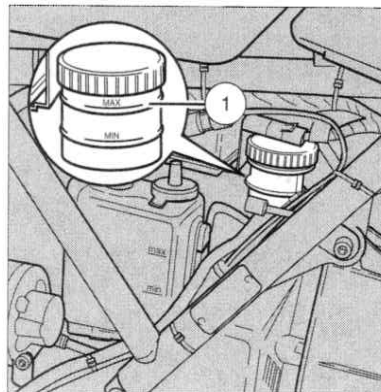
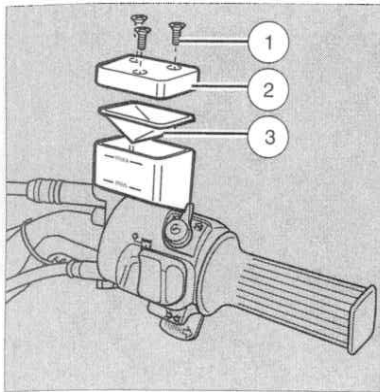

## Topping up brake fluid

### Front wheel brake

#### Tools required

Screwdriver with reversible blade.

#### Procedure

- Unscrew 3 phillips screws (1) (press cover down when doing this).
- Turn handlebars fully to the left. Take off cover (2) and rubber membrane (3).
- Top up brake fluid to upper edge of sight glass.
- Fit on rubber membrane and cover.
- Press on cover, turn handlebars fully to the right. Tighten phillips screws gently.

#### Warning:

Steam cleaning of the hydraulic brake system can affect brake fluid viscosity and is not recommended.

### Rear wheel brake

#### Procedure

- Take off the right battery cover (see page 70).
- Pull reservoir out of fixing clamp.
- Take off cover with rubber membrane.
- Top up brake fluid to MAX mark (1).
- Install in the reverse order.

#### Caution

Use only fresh brake fluid conforming to specification DOT 4.

Brake fluid may cause damage to paintwork!

Brake fluid is subject to high thermal stresses and absorbs moisture from the surrounding air.

#### For this reason:

Regardless of the distance you have covered, brake fluid should be replaced at least once a year.

In areas with mainly high temperatures and/or high air humidity, the brake fluid has to be replaced at least every 6 months.

#### Note

BMW (DOT 4) Brake Fluid is available from your authorized BMW motorcycle dealer.

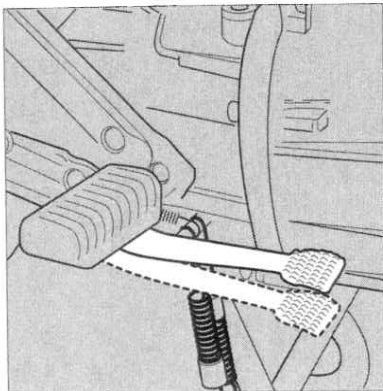

## Brake pedal travel

### Checking

The brake pedal travel is factory set and must not be altered.

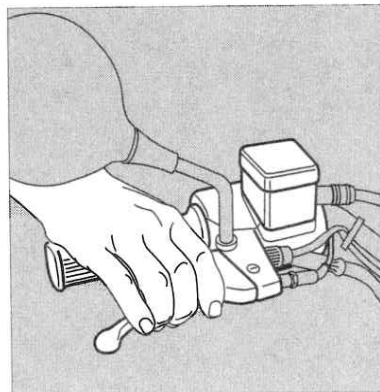

## Handbrake lever travel

### Checking

The handbrake lever travel is a design feature and cannot be altered.

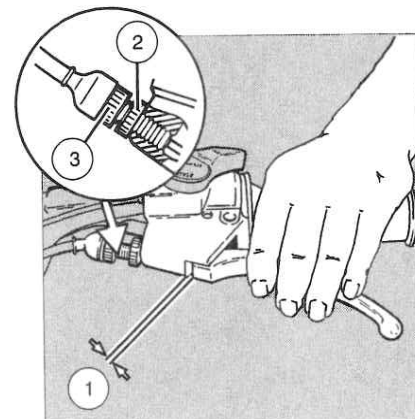

## Clutch lever travel

### Checking

- Pull lever until resistance is felt.
- Measure free travel. Should be (arrow): 4 +/- 0.5 mm.
- Slacken lock nut (2).
- Turn adjusting screw (3) to the left: reduces free travel.
- Turn adjusting screw (3) to the right: increases free travel.
- Tighten lock nut (2).

#### Note

Basic clutch adjustment takes place during the BMW Inspection.

#### Warning

Independent use of only the front or rear brake reduces stopping performance. Extreme braking may cause either wheel to lock, reducing control of the motorcycle. When possible, reduce speed or brake before entering a turn; closing the throttle or braking in midturn may cause wheel slip. Wheel slip will reduce control of the motorcycle.

When descending a long, steep grade, use engine compression braking by downshifting, with intermittent use of both brakes. Continuous brake application can overheat the brakes and reduce their effectiveness.

Sudden changes in the amount of free travel or a spongy feeling at the brake lever are signs of possible malfunctions in the hydraulic system.

Contact your BMW motorcycle dealer or qualified service technician immediately.

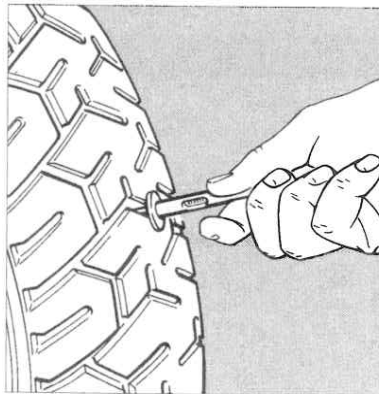
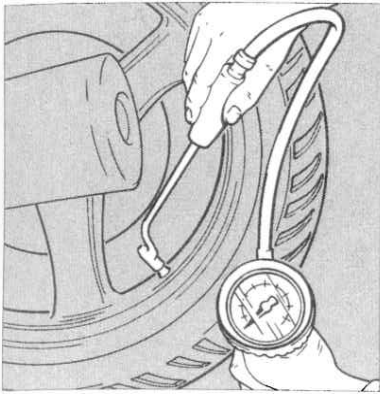

## Tire pressures

For your safety, periodically and certainly always before a trip, check your tire pressure, making sure it conforms to specifications provided below.

### Checking

- Tires cold
- Unscrew valve caps.
- Check/correct tire pressure.
- Screw on valve caps

#### One-up

front / rear 32/36 psi (2.2/2.5 bar)

#### Two-up

front / rear 36/42 psi (2.5/2.9 bar)

### Warning:

Incorrect tire pressure can considerably affect the driving characteristics of the motorcycle as well as reduce tire life!

## Tread depth

### Breaking in new tires

#### Warning

New tires have a smooth tread surface. You should therefore exercise particular care during the initial miles, waiting for the smooth factory tread surface to wear in before demanding maximum performance!

This break-in procedure is essential if the tires are to provide their full potential traction later on!

### Checking

- Checking tire tread.

#### Warning

Comply with official requirements governing minimum tread depth!

- Measure tread depth at the center of the tire.

BMW's minimum tread depth recommendation:

Front wheel	2 mm.
Rear wheel	3 mm.

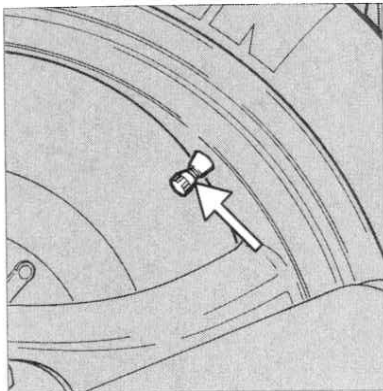

## Rims / valve caps

### Wheels

The wheels (rims) are an important safety item. Although the wheels are very strong, they could be damaged or distorted in an accident or by riding over an obstacle.

- Check that metal valve caps with seal are tightly seated on valves.

#### Warning:

Damaged wheels must always be replaced. Do not straighten or repair. Check your wheels regularly for damages.

Tire valves tend to open suddenly because of centrifugal forces at high speeds! Valve caps prevent a sudden loss of tire pressure!

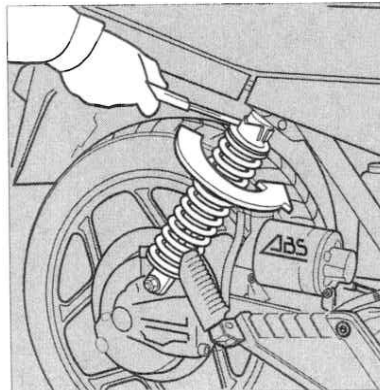

## Spring strut preload

### Adjusting spring preload:

- Adjust the spring preload of support springs to the load conditions with the aid of a spanner and extension (in motorcycle toolkit).
  - 1 "Normal" spring setting for solo operation.
  - 2 "Moderate" spring setting when riding two-up or with heavy luggage.
  - 3 "Firm" spring setting for extreme loads.

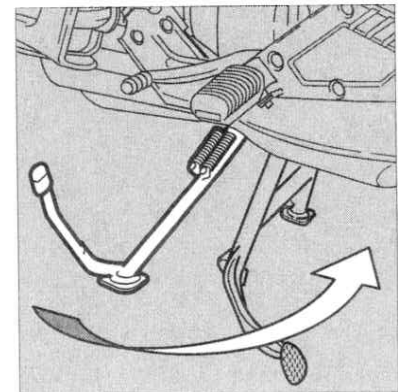

## Side stand

### Checking

- Position the motorcycle on center stand.
- Fold out sidestand as far as stop.
- Release sidestand.
- Stand (arrow) must retract automatically by the return springs.

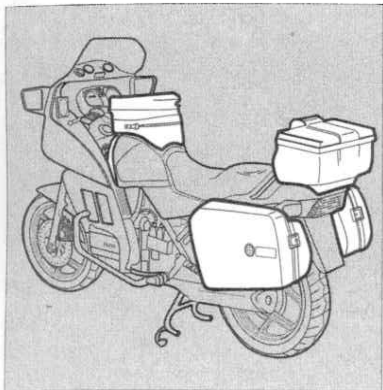

### Warning

Handling and stability of your motorcycle can be adversely affected by a number of factors.

In particular, excessive or unbalanced loading and the use of accessories not approved by BMW can lead to dangerous deterioration of the handling and stability characteristics of your motorcycle and thereby cause an accident.

Maximum speed with luggage system attached:

⇒ 130 km/h (80 mph)!

Ride behavior affected at high speeds.

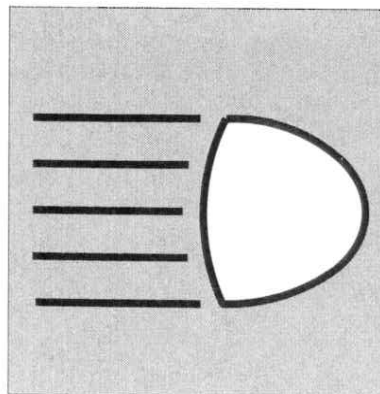

## Loads

Your motorcycle can be equipped with a specially developed luggage system.

The BMW luggage system consists of:

- Integral BMW cases
- BMW top case
- BMW tank-top rucksack

### Checking

- Do not exceed the maximum load for each case.

Maximum loads:

Per integral case (10 kg) 22 lbs  
35 litre top case (5 kg) 11 lbs

- Refer to system description for fitting and removing cases.
- Check that the fastenings are correctly located and tight.

### Warning

Do not exceed these specified load limits.

Stow heavy items of luggage in the bottom area of the tank top bag (alters center of gravity!).

Always make use of both side cases. Ensure that the weight is evenly distributed on both sides.

Do not exceed the permissible gross weight 1100 lbs (480 kg).

Permissible gross weight comprises:

- Motorcycle with full tank
- Rider
- Passenger
- Luggage
- Accessories

## Lights

Before starting the engine, it is a good practice to check the operation of the

- parking light
- low headlight beam
- high headlight beam

by holding a hand in front of the headlight lens.

As you have read on page 35, the tail and brake lights can be checked at monitor "△".

Pay special attention to condition of the turn indicators:

Turn indicator bulbs have to withstand severe loadings. A blown or damaged bulb can normally be detected by the increased flashing frequency of the turn signal telltale, and should be repaired or replaced immediately.

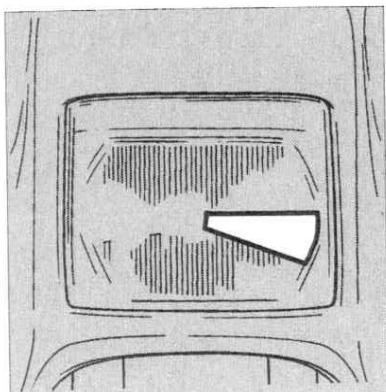

### For countries with leftside rule of the road.

Motorcycles for countries with leftside rule of the road are equipped with leftside asymmetrical low beam headlight.

The headlight beam is correctly aimed by analogy to the description on the left.

#### Note

Left cutoff point is determined by leftside asymmetrical low beam headlight.

If a motorcycle with right-hand asymmetrical low beam headlight is ridden temporarily in countries with leftside rule of the road, the wedge visible in the center of the lens must be blanked off with adhesive tape cut to shape.

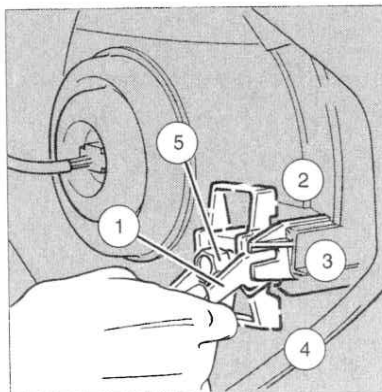

### Adjusting headlight beam angle

#### High/low setting

No tools required.

Set vertical beam angle of headlight by adjusting lever (1) to the right of headlight bulb, ahead of right fork tube

- Lever moved up (2):  
⇒ long beam angle.
- Lever in middle position (3):  
⇒ neutral beam angle.
- Lever in bottom position (4):  
⇒ short beam angle.

Perform fine setting with hexagon plastic screw (5).

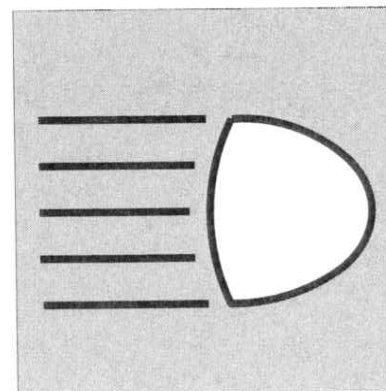

#### Note

Adjust high/low setting of beam so as not to blind oncoming traffic. Ensure that light beam illuminates road surface sufficiently far ahead.

# Starting – Riding – Parking

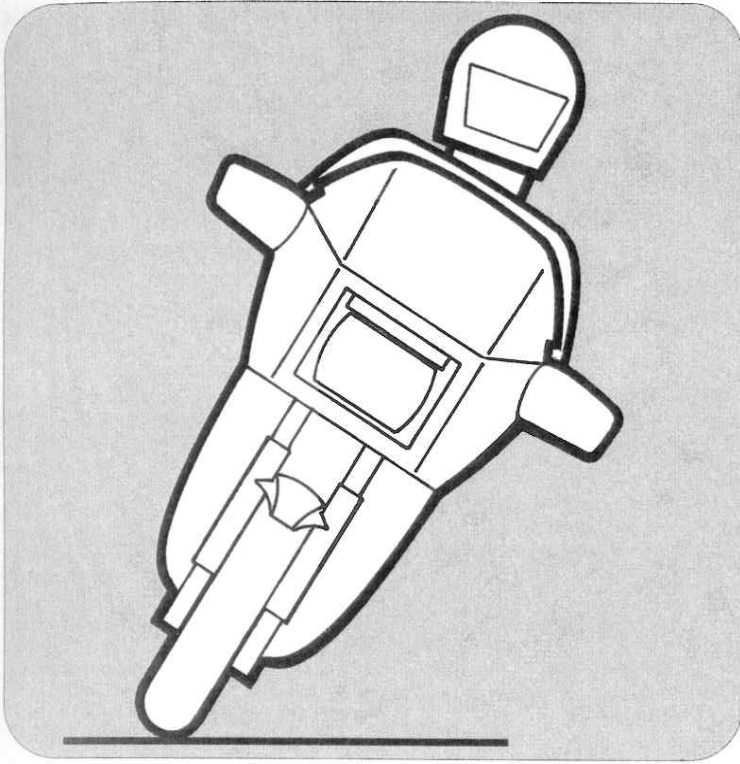

## And now we're off!

- Note on catalytic converter (38)
- Important ABS information (39)
- Some breaking-in rules (39)
- Engine speed limits (39)
- Rear light telltale (40)
- Coolant temperature (40)
- Battery charge current/alternator (40)
- Before starting the engine (41)
- Switching on ignition (41)
- Selecting neutral (41)
- Operating the choke (42)
- Pressing the starter switch (42)
- Resetting choke (42)
- Changing gears (43)
  - Moving off/shifting up (43)
  - Shifting down (43)
- Placing motorcycle on center stand (44)
- Moving motorcycle off center stand (44)
- Placing motorcycle on side stand (44)

( ) Figures in brackets ⇒ Page on which item is described.

38

## And now we're off! Starting – Riding – Parking

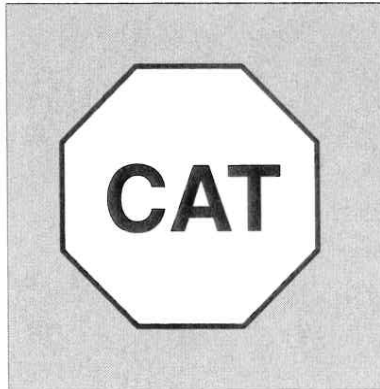

### Catalytic converter

#### Note

If the motorcycle has a catalytic converter:

Always use unleaded premium grade fuel.

Do not run the fuel tank empty.

Always have the prescribed maintenance work carried out.

If the engine misfires, switch it off immediately.

Only push-start when the engine is cold. It is preferable to use jump leads from another battery.

Do not allow the engine to run with any spark plug caps disconnected.

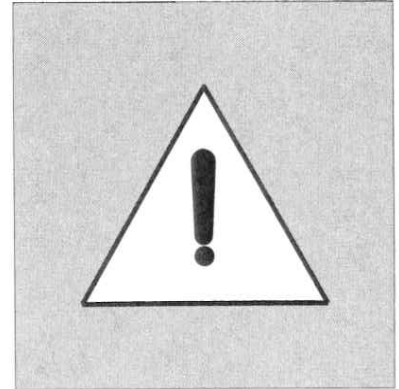

If the engine misfires or its power output deteriorates acutely, ride at low engine speed to the nearest authorized BMW motorcycle dealer.

#### Caution

High temperatures build up at the exhaust (with or without catalytic converter).

Make sure that no easily combustible material (for example hay, leaves, grass etc.) comes into contact with the hot exhaust system when the motorcycle is being ridden, idling or parked. If this material were to ignite and cause a fire, very serious injuries or damage could result.

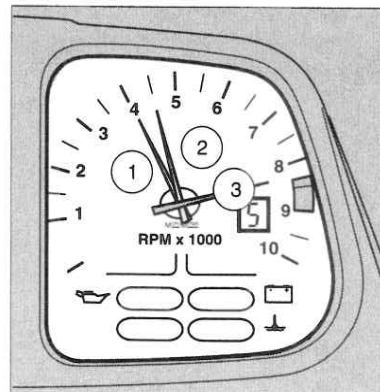
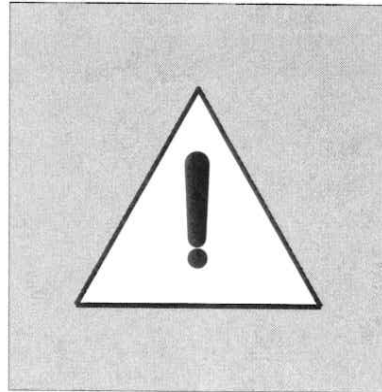
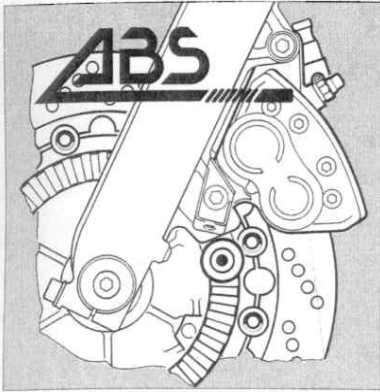

#### Caution

A motorcycle fitted with ABS should not be accelerated if the rear wheel is spinning to a considerable degree, as this results in a disparity between the wheel speed and the actual road speed.

If the brakes are applied immediately afterwards in this situation or the twist-grip turned back suddenly, the rear wheel decelerates rapidly. In extreme cases, the ABS system could interpret this as an emergency brake application and the system could be activated, delaying the build-up of brake pressure at the rear wheel for a brief period of max. 1 second.

The front brake remains under full ABS control regardless of this.

#### Some breaking-in rules

Carefully breaking-in your motorcycle can make a positive contribution to performance and operating life. For this reason, please pay close attention to the breaking-in rules and engine speed limits given below.

While breaking-in your motorcycle, frequently vary engine load and speed. Breaking-in is ideally carried out on roads with plenty of curves and hills, rather than high-ways.

Avoid, if possible, full brake applications until after the first 500 km (300 miles).

Break-in the tires for at least 500 km (300 miles), gradually increasing lean angles to wear off tire coatings.

Remember to have the first inspection performed after 1000 km (600 miles).

#### Engine speed limits

0 to 1000 km (600 miles)

max. 4000 rpm (1)

1000 to 2000 km (600 1200 miles)

max. 4500 rpm (2)

After 2000 km (1200 miles)

max. 8700 rpm (3)

#### Caution

Exceeding maximum engine speeds increases engine wear!

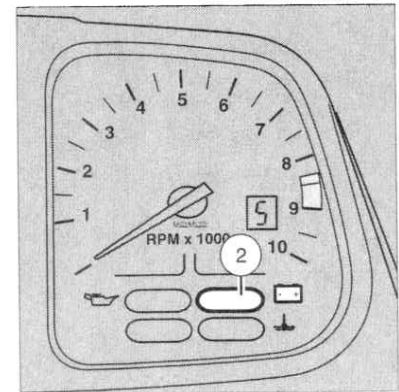
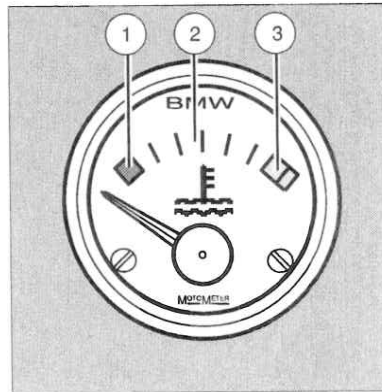
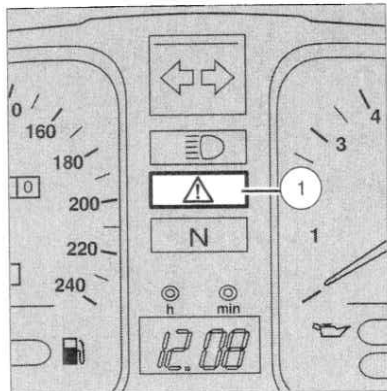

#### Rear light telltale

##### Checking

- Switch on ignition, parking lights/headlight. Light monitor will illuminate.
- Operate handbrake and brake pedal.
  - Telltale light (1) changes to flashing: Tail and brake light operating.
  - Telltale light does not flash: Bulb, wiring or switch faulty.
  - Telltale lights up when riding: Fault in tail light.

A tail light fault can only be detected when the parking lights or headlight are on.

#### Coolant temperature gauge

- 1 Engine cold (blue area): ride at low engine speeds.
- 2 Engine at operating temperature.
- 3 Engine overheating (red area): switch off immediately and allow to cool down, then contact your authorized BMW motorcycle dealer or qualified service technician.

#### Charge current/Alternator

Telltale light (2) goes out:

- after engine starts.
- at idling speed.

#### Note

If telltale light comes on while riding: Contact your BMW motorcycle dealer or qualified service technician. Battery will discharge quickly without input from the alternator.

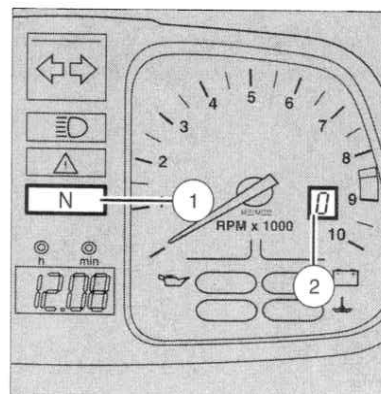
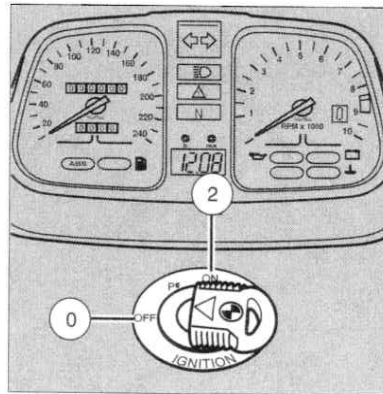
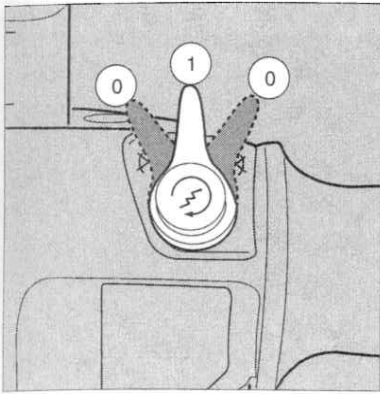

### Before starting the engine

- Place motorcycle on center stand.
- Check that the ignition kill switch is in position (1).

#### Note

Engine can only be started when kill switch is in position (1).

Ignition kill switch in positions (0):

Electrical circuits for ignition, injection system, fuel pump and starter are de-energized.

Emergency stop:

Move switch into position (0).

### Switching on ignition

- Use ignition key to turn ignition lock into On position (2).

### Selecting neutral

- Neutral telltale light (1) comes on.
- Digital gear display (2) in position ("0").

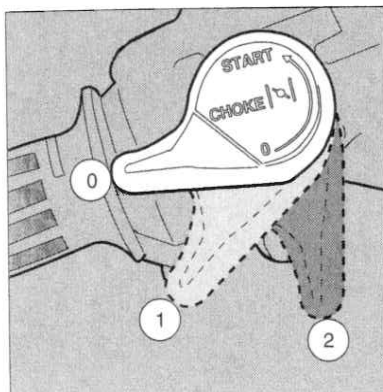

### Operating choke (increased cold starting speed)

Operate choke lever depending on engine or ambient temperature.

- Position 2 : below 32 °F (0 °C).
- Position 1 : above 32 °F (0 °C).
- Position 0 : engine at normal operating temperature.

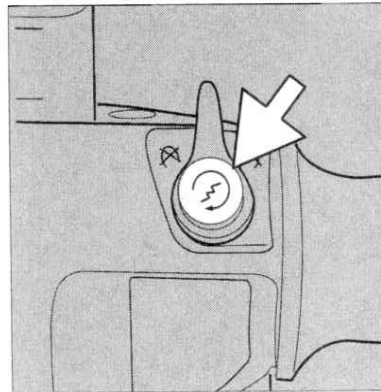

### Pressing starter switch

- Engine starts.
- If necessary, rotate throttle-twist grip gently.
- Pull-in clutch lever when starting engine at ambient temperatures below 32 °F (0 °C).

#### Note

Attempting to start engine with a low battery will cause starter relay to chatter audibly. Further attempts at starting will damage starter relay.  
**Charge battery!**

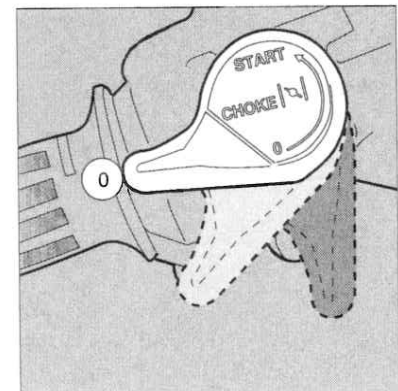

### Resetting choke (increased cold starting speed)

As engine runs more smoothly

- Move gradually back to position (0).

#### Note

**Do not run engine at fast speeds for too long.**

**Move back choke lever as soon as possible.**

**Do not warm up engine at idling speed. Move off immediately after starting.**

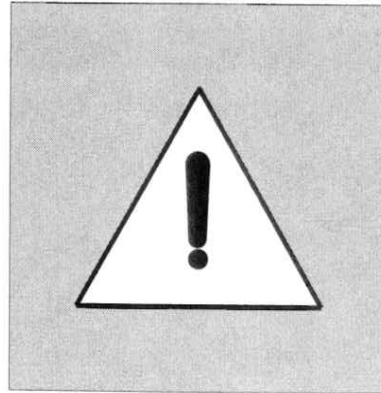
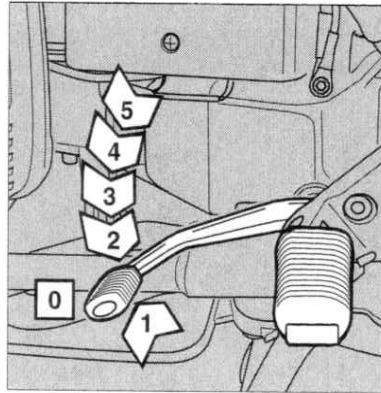
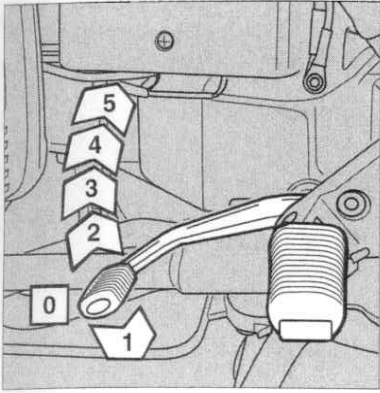

## Changing gears

### Moving off/shifting up

- Pull clutch lever.
- Press gear change pedal down fully.
- Engage clutch smoothly.
- Increase engine speed slightly when engaging clutch.
- After clutch engaged, accelerate.
- Similar procedure for shifting up into 2nd, 3rd, 4th and 5th gear.

### Caution

Do not allow clutch to slip when changing gears. Vary speed only with the throttle. Otherwise clutch may wear prematurely.

### Shifting down

- Close throttle twist grip.
- Pull clutch lever.
- Shift down into next lower gear.
- Engage clutch again slowly.
- After clutch engaged, accelerate.

### Note

Alter throttle opening to reduce the jerk caused by selecting lower gear. Digital gear display in revolution counter indicates gear selected. Select a lower gear if engine speed drops below 1500 rpm during normal riding.

### Warning:

When riding in wet or rainy conditions, or on loose surfaces, the ability to maneuver and stop will be reduced. All of your actions should be smooth under these conditions. Intentional sudden acceleration, braking, or turning may cause loss of control. For your safety, exercise extreme caution when braking, accelerating or turning.

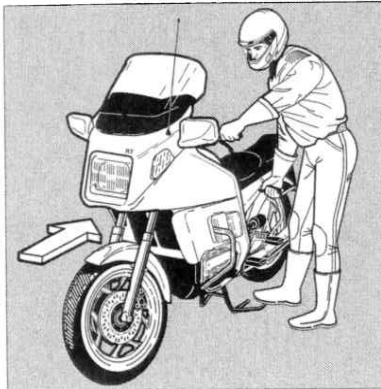

### Placing motorcycle on center stand

#### Warning:

To ensure safety, always retract both the center support and the kickstand before starting!

- Left hand on left handlebar twist grip.
- Right hand on retracting handle below seat edge.
- Right foot on arm of center stand.
- Transfer full body weight onto center stand arm.
- Pull motorcycle up and back onto center stand (arrow).
- Check that motorcycle is firmly supported.

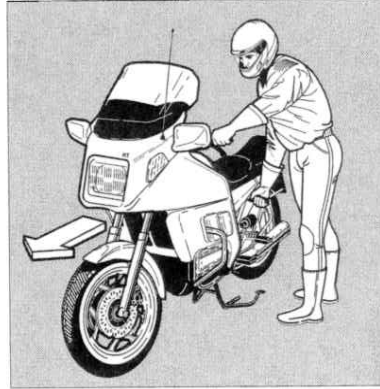

### Lowering motorcycle down off center stand

- Left hand on left handlebar twist grip.
- Right hand on retracting handle below seat edge.
- Push motorcycle forward off center stand (arrow).
- Check that center stand is fully retracted.

### Caution

Always ensure that the stand is resting on a firm level surface, to avoid the risk of the motorcycle falling over.

#### Warning:

Center stand must be fully retracted before setting off, or an accident may result.

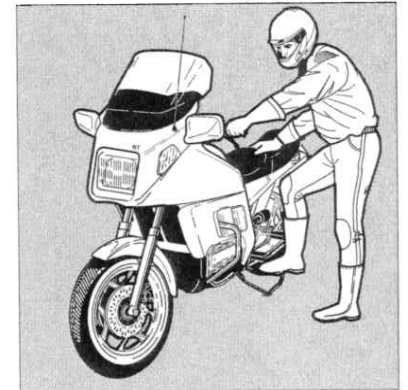

### Placing motorcycle on side stand

- Left hand on left handle bar twist grip.
- Right hand on dualseat.
- Extend side stand fully forward by means of its extension arm.
- Tilt motorcycle slowly onto stand.

### Caution

Make sure the stand is always resting on a firm surface with front fork extended, to avoid the risk of the motorcycle falling over.

On an incline, always position front of motorcycle pointing uphill with sufficient lean angle toward stand and engage 1st gear to prevent motorcycle from moving

#### Warning:

Side stand must be fully retracted before setting off, or an accident may result.



# Care and maintenance

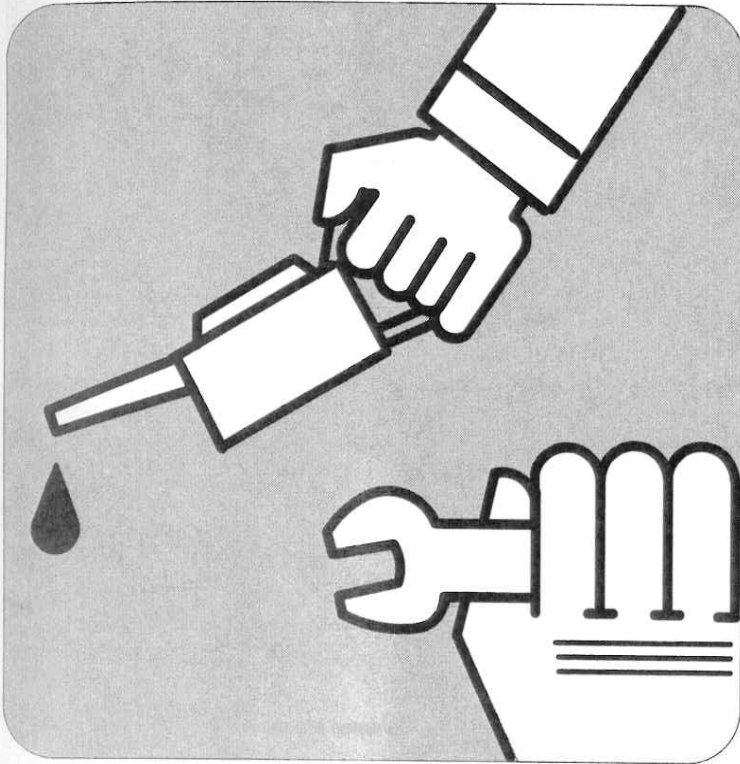

- General notes (46, 47)
  - Tool kit, repair kit for tubeless tires (48)
  - Removing/installing front wheel (49-51)
  - Removing/installing rear wheel (51-54)
  - Checking brake pads
    - Front wheel (55)
    - Rear wheel (56)
  - Electrical system:
    - replacing bulbs,
    - adjusting headlight beam angle,
    - aiming headlight beam,
    - replacing fuses (57-60)
  - Servicing battery (61, 62)
  - Troubleshooting table (63)
  - Cleaning/care (64, 65)
  - Check, care and cleaning windshield (66)
  - Storing motorcycle/restoring to service (67)
- ( ) Figures in brackets ⇒ Page on which item is described.

46

## Care and maintenance

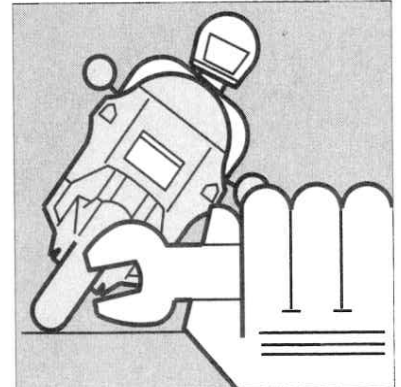
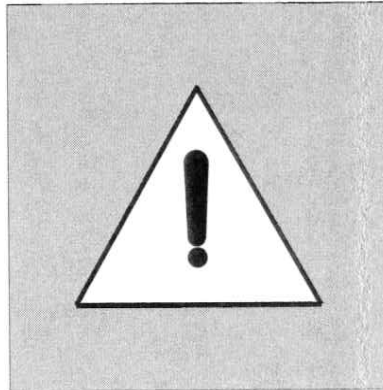

### General notes

The section which follows provides you with information regarding care and maintenance of your motorcycle. You will need certain technical knowledge and skill in using tools to perform the necessary care and maintenance jobs.

For further information, refer to the workshop manual or the circuit diagram file.

Only in this way can you be sure that the work which you perform will also bring you the desired success.

Your motorcycle reflects a high-technical standard. Special tools, special diagnostic and test systems as well as expert knowledge are required to keep your motorcycle in top shape.

Your BMW motorcycle dealer has the necessary technical expertise and properly trained staff. Take advantage of the help they can offer you. It will help ensure that your motorcycle is always in proper working order. Think of your own safety and trouble free operation of your motorcycle.

Do not attempt to perform more extensive work.

Have your motorcycle inspected and serviced at the specified intervals.

Use only Original BMW Parts and Accessories.

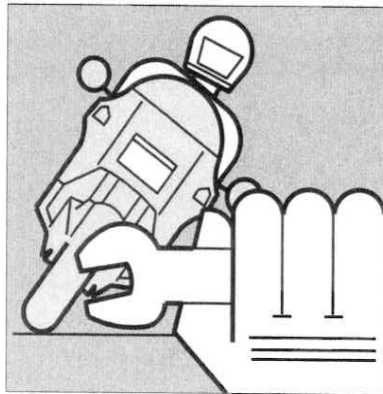
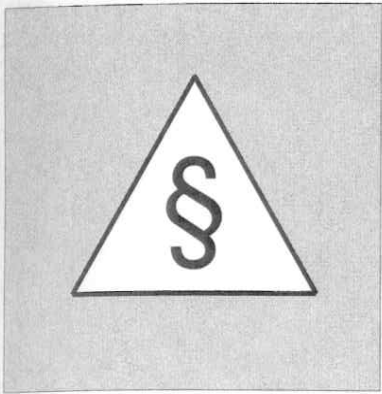

### Technical Modifications

Technical modifications are only permitted to a limited extent. Remember to comply with any legal requirements when modifying your motorcycle.

Your BMW motorcycle dealer will be glad to advise you on the merits of any modifications you have in mind, the legal situation and factory recommendations concerning specific technical modifications to your motorcycle.

### Original BMW Parts and Accessories

For safety reasons use only Original BMW Parts and Accessories.

BMW is unable to inspect and test every after-market part and accessory and therefore cannot assume any responsibility for such non-BMW parts.

Original BMW Parts are identical to the parts originally used in your new BMW motorcycle.

Original BMW Parts, (components and accessory items supplied by BMW AG Motorcycle Division and BMW of North America, Inc.) are covered by limited warranties\* against defects in material and workmanship.

\* See your Warranty Information/Service History booklet for details on BMW Limited Warranties.

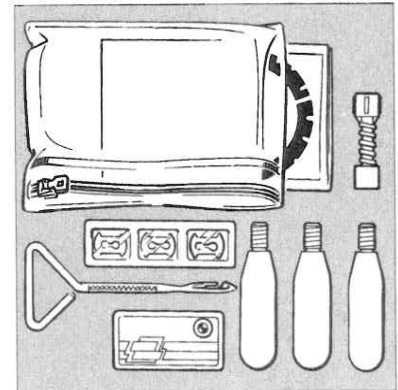
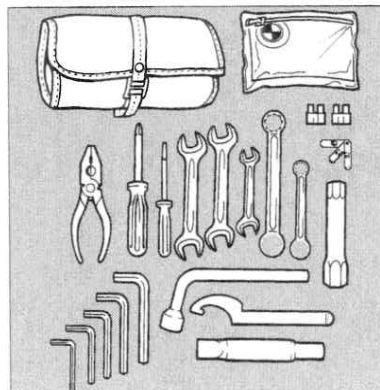
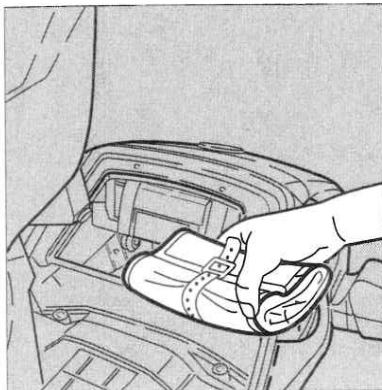

### Tool kit

- Toolkit in front right storage compartment in fairing.

#### Contents

- 1 leatherette case
- 1 multi-purpose pliers
- 1 large screwdriver (reversible blade)
- 1 small screwdriver
- 1 ABS feeler gauge
- 3 open-ended wrenches
  - 10 x 13 mm
  - 17 x 19 mm
  - 16 x 18 mm
- 2 ring wrenches
  - 10 x 12 mm
  - 17 x 19 mm

- 1 spark plug wrench
- 5 Allen keys
  - 3 mm,
  - 4 mm,
  - 5 mm,
  - 6 mm,
  - 8 mm.
- 1 box wrench for wheel studs
- 1 hook wrench for spring strut
- 1 tubular extension
- 1 flat fuses 15 A
- 1 flat fuses 7,5 A

### Repair kit for tubeless tires

Only suitable for punctures up to 4 mm (0.61 in) in diameter.

Please refer to instructions with kit for repair procedure.

#### Warning

**Maximum speed:**  
⇒ 60 km/h (37 mph) !

**Maximum distance:**  
⇒ 400 km (250 miles)!

**Always have tire renewed as soon as possible.**

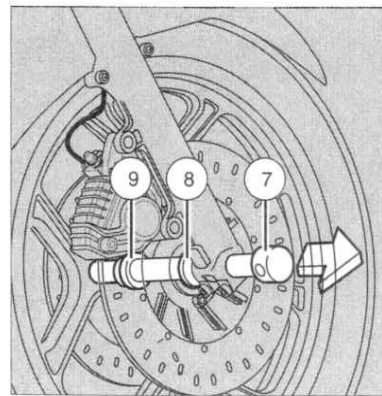
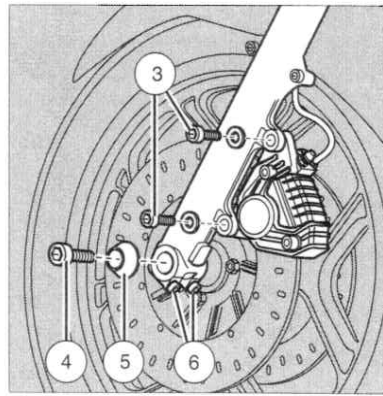
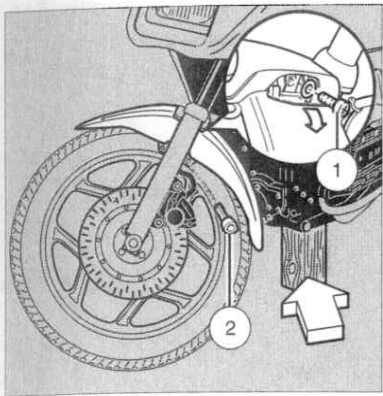

## Removing/installing front wheel

### Tools required

Allen keys

- 4 mm,
- 6 mm,
- 8 mm.

Open-ended wrench

- 13 mm.

Tubular extension

### Caution

**Do not damage brake discs and pads when removing.**

**Do not operate handbrake lever with wheel removed.**

**Keep wheel bearings free of dirt and moisture.**

### Procedure for removing wheel

- Place motorcycle on center stand.
- Position support below engine (arrow). front wheel exposed.
- Swing down the cover (arrow).
- Unscrew fastening bolts (1, 2).
- Take off fairing section.
- Mark installed position on tire or note direction of rotation arrow on tire.
- Unscrew fastening bolts (3) for left/right brake caliper.
- Unscrew axle bolt (4).
- Slacken axle clamp bolts (6).
- Withdraw stub axle (7).
- Take out left/right spacing bushings (8, 9).
- Take off brake calipers.
- Run front wheel out to the front.

50

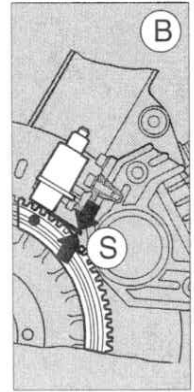
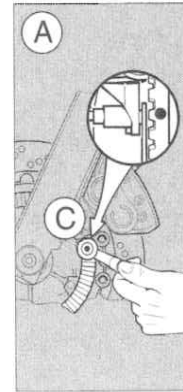
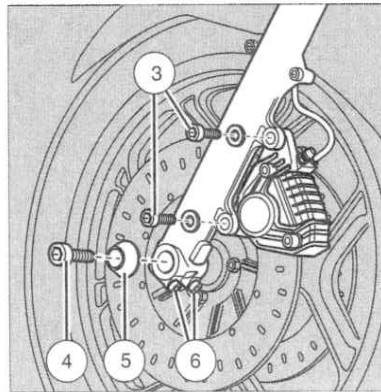
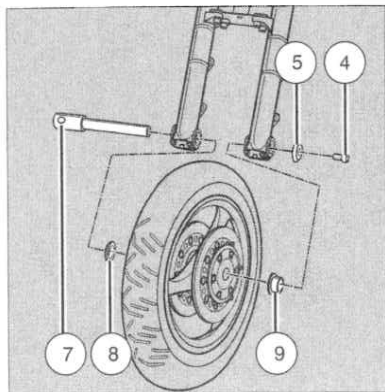

### Procedure for installing wheel

- Roll front wheel in between forks. Pay attention to direction of rotation arrow or marking on tire.
- Fit left/right brake caliper onto brake discs.
- Insert spacing bushings.  
On left in direction of travel: **wide bushing (9)**;  
On right in direction of travel: **narrow bushing (8)**.
- Grease stub axle (7).
- Install stub axle from the right (raising wheel at same time).
- Fit on profile disc (5).
- Tighten axle bolt (4).
- Install brake calipers with mounting brackets and tighten bolts (3).
- Tighten left-hand axle clamp bolts (6).
- Remove support from below engine.
- Vigorously compress telescopic forks several times with handbrake applied.
- Tighten right-hand axle clamp bolts.

### Check ABS sensor gap

#### Note

**Extreme care must be taken when carrying out this work in order not to interfere with the correct functioning of the system.**

#### Caution

**After fitting wheel, it is essential to check the gap (S) at the point of the maximum distance (chisel punch point "C"), and have it set by your BMW motorcycle dealer or a qualified service technician if necessary.**

#### Gap (S) Front wheel

with floating disc (A)	0,50 ... 0,55 mm
with fixed disc (B)	0,60 ... 0,65 mm

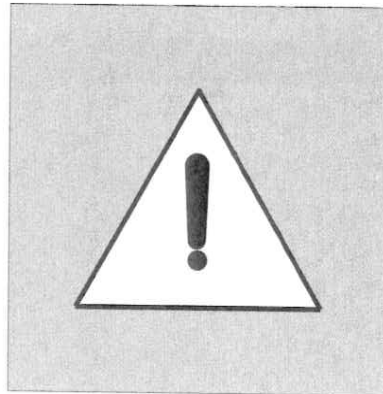
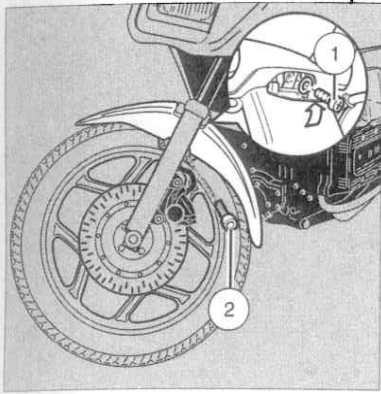

- Install fairing sections.
- Screw in fastening bolts (1, 2) with washers. Tighten gently.
- Close the cover (arrow) for retaining screw (1).

#### Tightening torques

- Axle bolt (6)  
⇒ 33 Nm (24 ft.lb.)
- Brake caliper bolt (4)  
⇒ 32 Nm (23 ft.lb.)
- Axle clamp bolts (8)  
⇒ 14 Nm (10 ft.lb.)

#### Caution

Do not damage brake discs and pads when installing.  
Do not operate handbrake lever with wheel removed.  
Have tightening torques checked by your BMW motorcycle dealer or a qualified service technician.

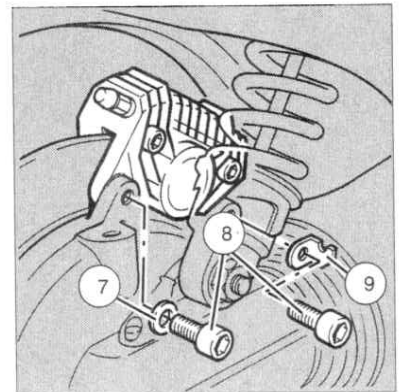
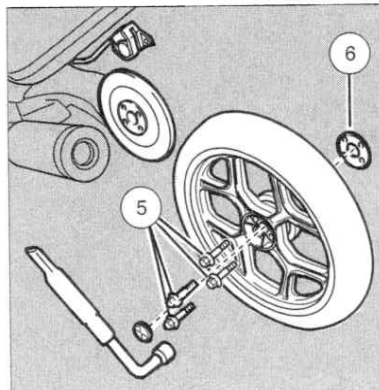
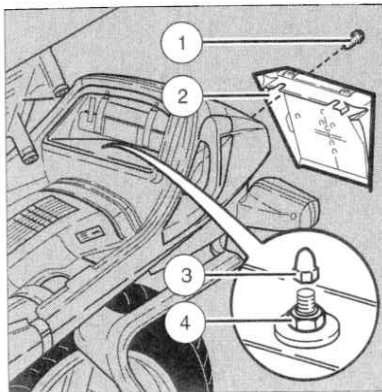

### Removing/installing rear wheel

#### Tools required

- Open ended wrench
  - 10 mm.
- Allen keys
  - 8 mm.
- Screwdriver with reversible blade.
- Box wrench for wheel studs.
- Tubular extension

#### Caution

Do not damage brake discs and pads when removing.  
Do not operate brake pedal with wheel removed.

#### Procedure for removing wheel

- Place motorcycle on centre stand.
- Engage first gear.
- Take out the 2 Phillips-head screws (1) for the rear wheel cover (number plate holder) (2).
- Swing up the dualseat and remove the storage compartment cover.
- Pull off the 2 protective caps (3) at left and right, and **slacken off** the 2 hex nuts (4) but do not unscrew them fully.
- Pull the rear wheel cover off to the rear.

- Take out the 5 wheel studs (5) and take off the taper rings. (If necessary, take off the wheel stud cover first.)
- Detach the cable from the angled holder (9).
- Take out the 2 brake caliper screws (8).
- Lift the rear wheel away from its centering location.
  - Note spacing washer (6).
- Carefully remove the brake caliper from the brake disc.
- Roll the rear wheel out rearwards.

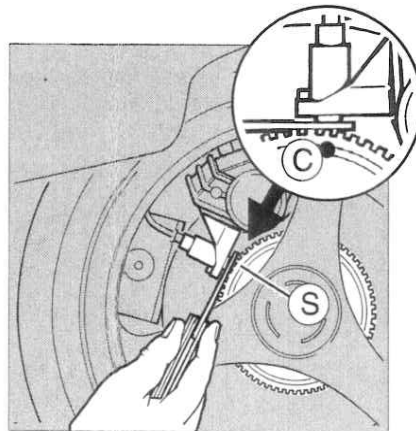
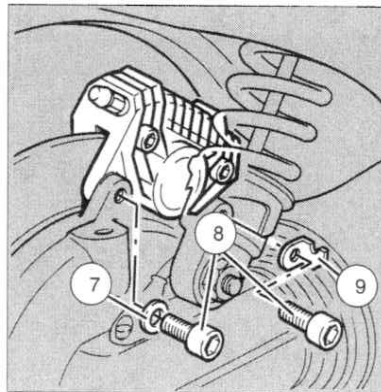
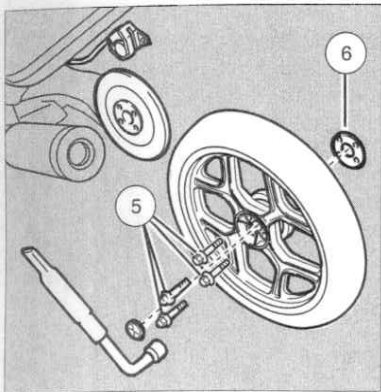

#### Procedure for installing wheel

- Check that the wheel centering location, wheel hub contact faces and spacing washers are free from grease.
- Push spacing washer (6) on to the wheel centering location.
- Carefully push the brake caliper on to the brake disc.
- Insert the rear wheel into the bore of the centering location.
- Screw in the wheel bolts (5) with tapered rings until hand-tight, then tighten them to the pre-load torque in a crosswise pattern.
- Tighten wheel bolts (5) to specified torque in a crosswise pattern. (If necessary, insert the wheel stud cover.)

- Insert the brake caliper screws (8) with their washers (7) and the angled holder (9) for the pulse transmitter cable.
- Attach the pulse transmitter cable to holder (9).

#### Check ABS sensor gap

##### Note

Extreme care must be taken when carrying out this work in order not to interfere with the correct functioning of the system.

##### Caution

After fitting wheel, it is essential to check the gap (S) at the point of the maximum distance (chisel punch point "C"), and have it set by your BMW motorcycle dealer or a qualified service technician if necessary.

##### Gap (S)

Rear wheel 0,60 ... 0,65 mm

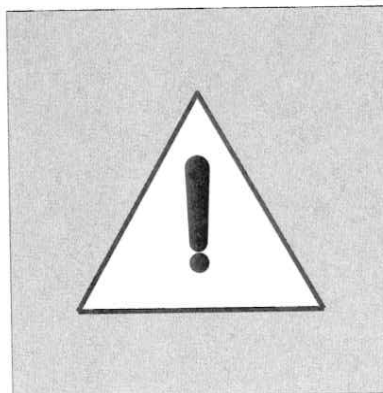
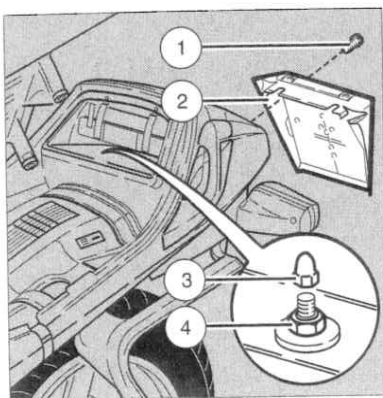

- Install the rear wheel cover (2). Note plastic washers.
- Tighten hex nuts (4) at left/right in storage compartment, and attach the protective caps (3).
- Close the storage compartment and swing down the dualseat.

#### Pre-load torque

- Wheel bolts (5)  
⇒ 50 Nm (36 ft.lb.)

#### Tightening torques

- Wheel bolts (5)  
⇒ 105 Nm (76 ft.lb.)
- Brake caliper bolts (9)  
⇒ 32 Nm (23 ft.lb.)

#### Caution

Do not damage brake discs and pads when installing.

Do not operate brake pedal with wheel removed.

Use only wheel and central bolts with the same length code number.

Have tightening torques checked by your BMW motorcycle dealer or a qualified service technician.